

INSTRUCTION MANUAL
FOR
MODEL NRD-535
(also for NRD-635DG)



HF RECEIVER

Congratulations on your purchase of the Japan Radio Company NRD-535 HF Receiver!

This product is the most advanced amateur/SWL receiver available today. It represents the state-of-the-art in design and manufacturing technology, based on the achievements and experience gained by JRC in over 75 years of producing professional radio communications equipment.

Before using your NRD-535, please read through this manual. It will provide much insight on the radio's many advanced operations and will ensure that you are able to obtain optimum performance from your new receiver.

Like all JRC products, the NRD-535 is manufactured under the strictest quality control methods and should provide many years of enjoyment. If you experience any problems or damage, please contact your dealer or nearest JRC office immediately.

NOTE: *The cardboard box that the NRD-535 is shipped in was designed to provide maximum protection during transportation. Therefore, we recommend that you save this carton in case you have to ship the radio at a later date. We also recommend that this box be placed in another, larger carton during shipment.*

ACCESSORIES

The NRD-535 includes the following accessory items. Please check that all items were received:

- Instruction Manual (1)
- PL-259 Coaxial Plug (1)
- Headphone Plug (1)
- Record Plug (1)
- RCA-type Plug (5)
- Fuse (1A) (1)
- DC Power Cord (1)
- AC Power Cord (1)

CAUTIONS

1. A small amount of current is always present when the NRD-535 is plugged in, even if the POWER switch is set to OFF. This is to maintain the internal clock settings. This is especially important if the radio is operated under battery power. If you do not plan to use the receiver for an extended period, you may wish to disconnect the AC or DC cable. Please note that such disconnection will clear the current clock settings.
2. The NRD-535 is capable of operating from a wide range of AC voltages. Please check the carton to determine the voltage setting as shipped from the factory. If the power source that you wish to operate the radio from is different than that for which the radio is set, please refer to Section 3 of this manual for detailed instructions on changing the VOLTAGE SELECTOR.
3. When operating from a DC power source, always use the DC cable that was furnished with the radio. If you must use a different cable, be certain that a 3A fuse is inserted in the power line.
4. Never connect an AC power line to the TIMER OUT relay terminal on the NRD-535's rear panel.

OPTIONAL UNITS

Please note that the NRD-535 uses certain optional units that are common to the NRD-525 receiver and JST-135 transceiver. Therefore, the instruction sheets that come with these units may not pertain to the NRD-535, and should be ignored. Please see Section 8 of this manual for full details regarding installation and operation of optional units.

DELUXE MODEL (NRD-535D)

The NRD-535 is available in both Standard and Deluxe configurations. The Deluxe model, NRD-535D, is identical to the Standard model, except that the following units have been installed at the time of production:

- BWC Unit (CFL-243)
- ECSS Unit (CMF-78)
- Narrow 1.0 kHz Filter (CFL-233)

This manual is applicable to both models since it covers the operation of the above units. Please ignore the installation instructions for these units if you own the NRD-535D.

■ CONTENTS

SECTION 1: FEATURES 4

SECTION 2: SPECIFICATIONS 6

SECTION 3: INSTALLATION 7

 3.1 Installation Location 7

 3.2 Installing the Receiver 7

SECTION 4: OPERATING CONTROLS 9

 4.1 Front Panel 9

 4.2 Rear Panel 15

SECTION 5: OPERATING THE NRD-535 17

 5.1 Receiving Different Types of Signals 17

 5.2 Memory Channel Operations 19

 5.3 Scan and Sweep Operations 20

 5.4 Clock/Timer Operations 21

 5.5 External Control Using Computer Interface 22

 5.6 User Definitions 25

 5.7 RTTY Demodulator 27

SECTION 6: ADJUSTMENT AND MAINTENANCE 28

 6.1 Adjustment 28

 6.2 Maintenance 28

SECTION 7: TROUBLESHOOTING 30

 7.1 Simple Problems 30

 7.2 More Serious Problems 30

SECTION 8: OPTIONAL UNITS 32

 8.1 Introduction 32

 8.2 Removing Covers 36

 8.3 Removing Internal Units 36

SECTION 9: BLOCK DIAGRAM 38

SECTION 10: CIRCUIT DIAGRAMS 39

OPERATING CONTROLS

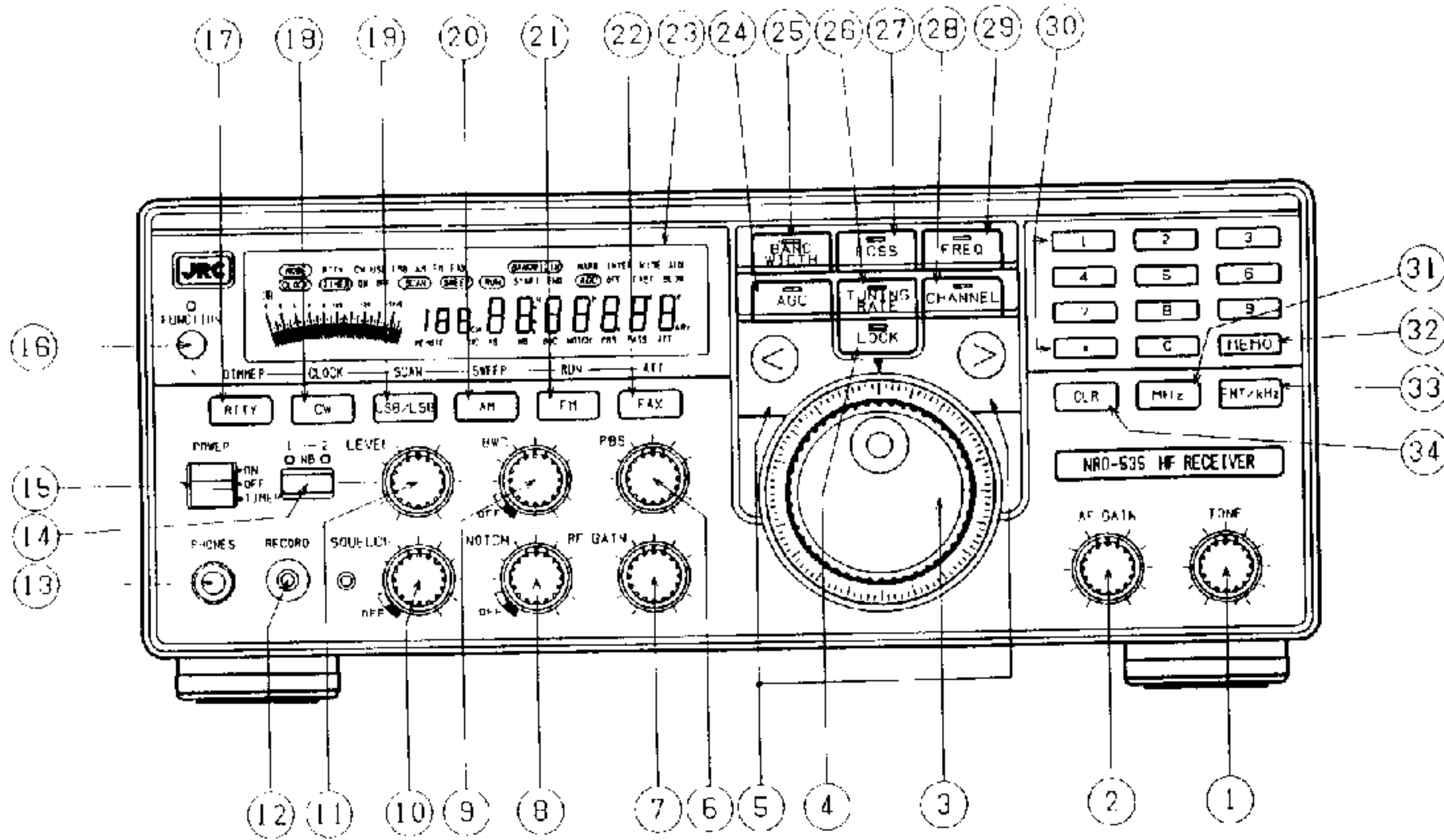

FRONT PANEL

- ① TONE CONTROL
- ② AF GAIN CONTROL
- ③ MAIN TUNING DIAL
- ④ LOCK BUTTON
- ⑤ UP/DOWN BUTTON
- ⑥ PBS (PASSBAND SHIFT) CONTROL
- ⑦ RF GAIN CONTROL
- ⑧ NOTCH CONTROL
- ⑨ BWC (BANDWIDTH CONTROL)
- ⑩ SQUELCH CONTROL
- ⑪ NB (NOISE BLANKER) LEVEL CONTROL
- ⑫ RECORD (OUTPUT) JACK
- ⑬ PHONES (HEADPHONE) JACK
- ⑭ NB (NOISE BLANKER) BUTTON
- ⑮ POWER/TIMER ON-OFF SWITCH
- ⑯ FUNCTION BUTTON
- ⑰ RTTY MODE (DIMMER) BUTTON
- ⑱ CW MODE (CLOCK) BUTTON
- ⑲ USB/LSB MODE (SCAN) BUTTON
- ⑳ AM MODE (SWEEP) BUTTON
- ㉑ FM MODE (RUN) BUTTON
- ㉒ FAX MODE (ATTENUATOR) BUTTON
- ㉓ FLUORESCENT DISPLAY
- ㉔ AGC (AUTOMATIC GAIN CONTROL) BUTTON
- ㉕ BANDWIDTH BUTTON
- ㉖ TUNING RATE BUTTON
- ㉗ ECSS (EXCITED CARRIER, SELECTABLE SIDEBAND) BUTTON
- ㉘ CHANNEL BUTTON
- ㉙ FREQ (FREQUENCY) BUTTON
- ㉚ NUMERICAL KEYPAD
- ㉛ MHz BUTTON
- ㉜ MEMO BUTTON
- ㉝ ENT/kHz BUTTON
- ㉞ CLR (CLEAR) BUTTON

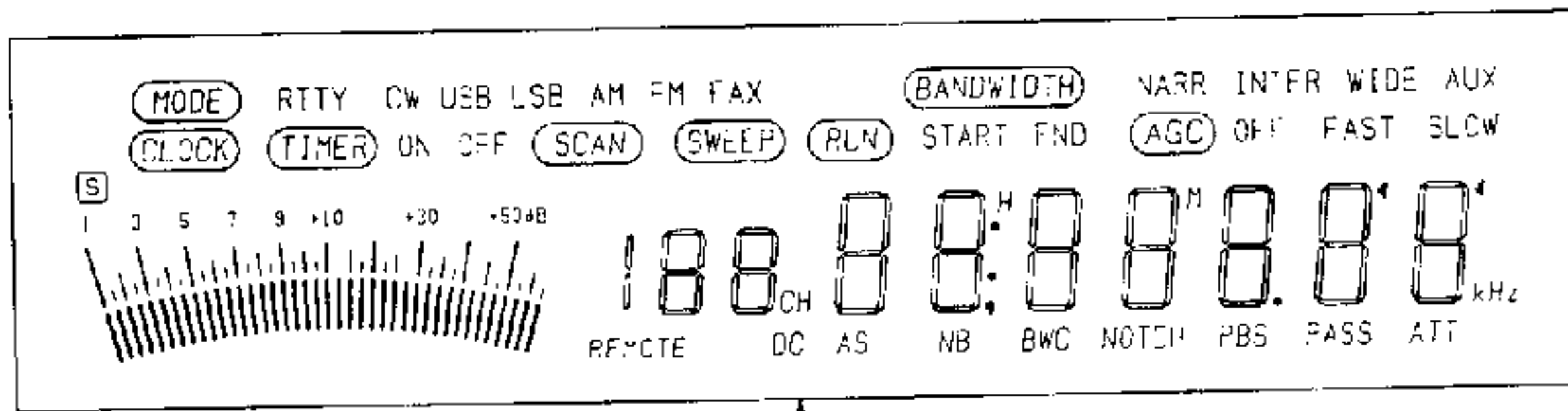

⑲

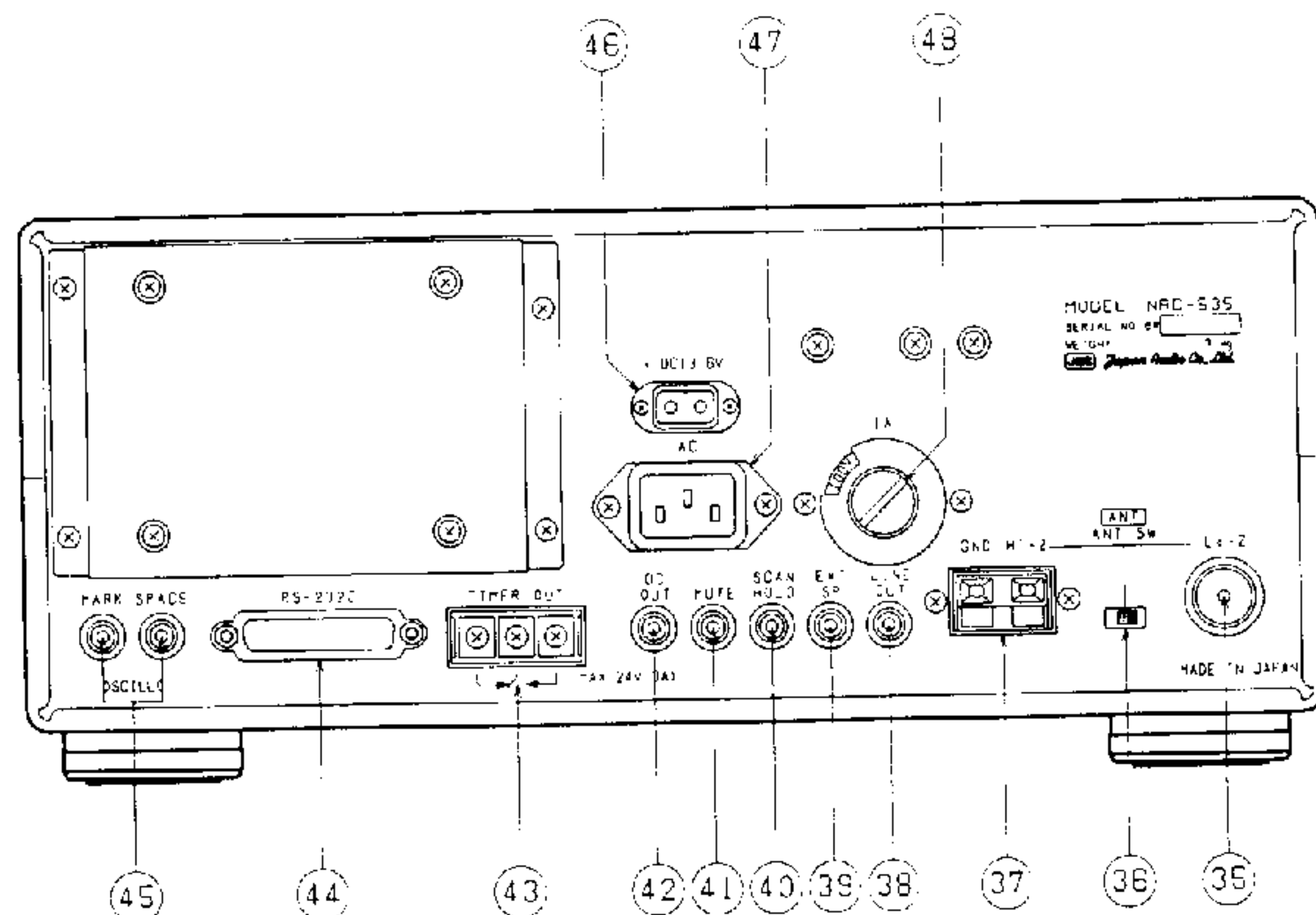

REAR PANEL

- ⑳ ANT Lo-Z (LOW IMPEDANCE ANTENNA) CONNECTOR
- ㉑ ANT (ANTENNA) SWITCH
- ㉒ ANT Hi-Z (HIGH IMPEDANCE ANTENNA) CONNECTOR
- ㉓ LINE OUT JACK
- ㉔ EXT SP (EXTERNAL SPEAKER) JACK
- ㉕ SCAN HOLD JACK
- ㉖ MUTE JACK
- ㉗ DC OUTPUT JACK
- ㉘ TIMER OUT TERMINAL
- ㉙ RS-232C PORT
- ㉚ RTTY MARK/SPACE INDICATOR JACKS
- ㉛ DC13.8V (DC POWER) CONNECTOR
- ㉜ AC POWER CONNECTOR
- ㉝ AC FUSE AND VOLTAGE SELECTOR

SECTION 1: FEATURES

1. HIGH SENSITIVITY AND DYNAMIC RANGE

An RF amplifier with four parallel-connected JFETs and a double balanced mixer with quadruple-connected JFETs provide high sensitivity and dynamic range, improving the ability to pick out a weak signal among many stronger ones.

2. ELECTRONIC RF TUNING SYSTEM

The double tuning circuit in the receiver's front end employs an advanced variable tuning system, also found in JRC's professional receiving equipment. The circuit is continuously controlled by the NRD-535's microprocessor to tune the front end to the receive frequency, while greatly attenuating undesired out-of-band signals.

3. 1 Hz TUNING RESOLUTION

The PLL synthesizer section employs JRC's custom DDS (Direct Digital Synthesis) ICs, and is controlled by a high performance magnetic-type rotary encoder incorporated in the main tuning dial system. This high speed synthesizer is capable of tuning increments as small as 1 Hz.

4. ALL-MODE OPERATION

Receiving modes include AM, USB, LSB, CW, RTTY, FAX and FM. With the optional CMH-530 RTTY Demodulator installed, CCITT No. 2 specified 5-level Baudot signals may be converted and accessed via the RS-232C Serial Interface.

5. EXALTED CARRIER, SELECTABLE SIDEBAND (ECSS)

With ECSS, a double-sideband AM signal is processed to enhance reception of shortwave and mediumwave broadcast stations. By eliminating one of the sidebands (the one that is most prone to interference) and replacing the carrier with an improved carrier generated by the receiver, the interference is eliminated without switching to a narrow bandwidth filter. Thus, the signal retains its audio fidelity, while minimizing carrier distortion and other fading effects. (The ECSS Unit, CMF-78, is optional except for NRD-535D deluxe model.)

6. DUAL NOISE BLANKERS

The noise blanker (NB) can operate in either wide or narrow mode, with full control of blanking level. Wide mode is effective for eliminating woodpecker noise, and the narrow mode is used to combat electrical noise from automobile ignitions, motors, fans, etc.

7. NOTCH FILTER

An IF notch filter removes annoying carriers and heterodynes from the receiver's passband.

8. PASSBAND SHIFT (PBS)

The PBS control shifts the apparent center frequency of the receiver's IF filter, without changing the overall bandwidth of the filter. This allows the user to "move" the filter passband up or down in frequency, until the interfering signal is outside of the passband.

9. BANDWIDTH CONTROL (BWC)

The BWC continuously reduces the overall IF bandwidth without changing the center frequency of the passband. This is often necessary when listening on crowded bands with many strong signals present. (The BWC Unit, CFL-243, is optional except for NRD-535D deluxe model.)

10. PERSONAL COMPUTER CONTROL

All NRD-535 models are equipped with a built-in RS-232C Serial Interface, allowing direct linking of the receiver's CPU to a personal computer. Frequency, mode, filter, BWC and other receiver parameters can be set, plus information such as memory channel data, S-meter reading and RTTY data (with the optional CMH-530 RTTY Demodulator unit) can be retrieved from the NRD-535.

11. INTERNAL CLOCK/TIMER

Timer operation allows the NRD-535 to be programmed to turn on at a specified time, and also can turn on external tape recorder via timer controlled relays on rear panel.

12. 200 CHANNEL MEMORY CAPACITY

Up to 200 tunable memory channels are available to store frequency, mode, filter, AGC and attenuator settings. In addition, RTTY Demodulator settings (baud rate, shift width and polarity) can be stored (if optional CMH-530 is installed). The memory unit is composed of a C-MOS RAM IC backed up by a lithium battery.

13. SUPERB ERGONOMICS AND OPERABILITY

The NRD-535 was designed with the operator in mind. On the front panel, all basic operating controls are intuitive. The direct entry keypad can be used to select a channel or input a desired frequency. Mode can be selected with the press of a single button. Advanced users can further tailor the NRD-535's operation to their own prefer-

ence by several User Definition Functions.

14. STATE-OF-THE-ART MANUFACTURING PROCESS

Full modular construction and liberal use of chip type surface-mount components reflects JRC's professional design and manufacturing heritage. Automated production results in excellent quality control while reducing cost. In addition, the modular design simplifies troubleshooting and improves reliability and serviceability.

SECTION 2: SPECIFICATIONS

Operating frequency	0.1 to 30 MHz
Modes of operation	AM, USB, LSB, CW, RTTY, FAX and Narrow FM
Frequency stability	±2 ppm or better after 5 to 50 minutes warm-up period (±0.5 ppm with optional CGD-135 High Stability crystal oscillator unit installed)
Tuning increments	Selectable .001, .01 and .1 kHz steps with main tuning dial; .01, .1 and 1 kHz steps with up/down buttons
Memory capacity	200 tunable memories
Receiving system	Triple superheterodyne (double superheterodyne for FM)
Intermediate frequencies	First IF: 70.455 MHz Second IF: 455 kHz Third IF: 97 kHz

Sensitivity:

BAND	RTTY/FAX/		
	CW/SSB	AM	FM
0.1-0.5 MHz	14 dBμ (5 μV)	24 dBμ (15.8 μV)	—
0.5-1.6 MHz	6 dBμ (2 μV)	16 dBμ (6.3 μV)	—
1.6-30 MHz	-10 dBμ (0.32 μV)	6 dBμ (2 μV)	-6 dBμ (0.5 μV)

S/N: 10 dB; Bandwidth: INTER; Modulation: 400 Hz, 30 %, AM mode (12 dB SINAD FM)

Selectivity:

BANDWIDTH	-6 dB		-60 dB	
AUX	12 kHz or more	—		
WIDE	4 kHz or more	10 kHz or less		
INTER	2 kHz or more	6 kHz or less		
NARR	1 kHz or more	3 kHz or less		
FM	12 kHz or more	—		

NOTE: The NARR bandwidth characteristics measured with CFL-233 filter installed.

Dynamic range	106 dB (300 Hz bandwidth)
Image rejection	70 dB or better
IF rejection	70 dB or better
PBS variable range	±1 kHz
NOTCH attenuation	40 dB or more
Antenna impedance	50Ω at Lo-Z terminal 600Ω at Hi-Z terminal
Attenuator	Approx. 20 dB
AGC characteristics	10 dB or less AF output variation for antenna input signal change from 3 μV to 100 mV
AF output	Speaker output: 1 watt or more (at 4Ω load and 10% distortion) Line output: 1 mW or more (at 600Ω load and 10% distortion)
RS-232C interface	4800 baud, 8 data bits, 1 start bit, 1 stop bit, no parity
Power requirements	100/120/220/240 V AC, ±10%, 35 VA or less 12 to 16 V DC (13.8 V standard), 25 W max (approx. 2 A)
Dimensions	Width 330 mm × Height 130 (143) mm × 287 (324) mm. Values in parenthesis include projections
Weight	Approx. 9 kg

NOTE: The above ratings are based on standard JAIA measuring standards. All ratings are subject to change to increase performance without notice.

SECTION 3: INSTALLATION

3.1 INSTALLATION LOCATION

Always place your NRD-535 in a well ventilated area and avoid places that are exposed to direct sunlight, hot air, dust, vibration and moisture. Sufficient space should be left at the rear of the receiver, and the ventilation slots on the top cover should not be blocked.

3.2 INSTALLING THE RECEIVER

Before operating the NRD-535, the following procedures should be followed. Please refer to Figure 3-2.

3.2.1 ANTENNA CONNECTION

For optimum performance, an outdoor antenna should be used. Many different types of antennas, such as dipoles, longwires, yagis, etc. For those who have limited space or can not install an outdoor antenna, several 'active' antennas are also available. Please consult with your dealer to decide which antenna best meets your needs.

The NRD-535 has terminals on the rear panel for both high (600 Ω) and low (50 Ω) antennas, selectable by the switch located between the two terminals. Typically, antennas that are fed with coaxial cable will use the Lo-Z connector, and antennas that have a single wire feed line, or use twin-lead feed line will be connected to the Hi-Z terminal.

3.2.2 GROUNDING THE RECEIVER

It is strongly recommended that all amateur radio equipment be properly grounded to prevent electrical shock and related hazards, as well as to reduce static interference from other devices. A copper plated steel rod 6 to 8 feet in length is recommended for use as an outdoor ground rod. Heavy copper wire or braid should be attached from the ground rod to the NRD-535's GND terminal on the rear panel.

For increased protection from lightning and heavy static discharges, several antenna line protection devices are available. Although these may not protect against a direct lightning hit, they can reduce the danger from nearby strikes.

3.2.3 CONNECTING POWER

For operation from an AC power source, you may use the supplied AC power cable by connecting it to the AC power connector on the rear panel.

Please check that the power source matches the power setting indicated on the voltage indicator on the rear panel (see Fig. 3-1). To

change the operating voltage of the NRD-535:

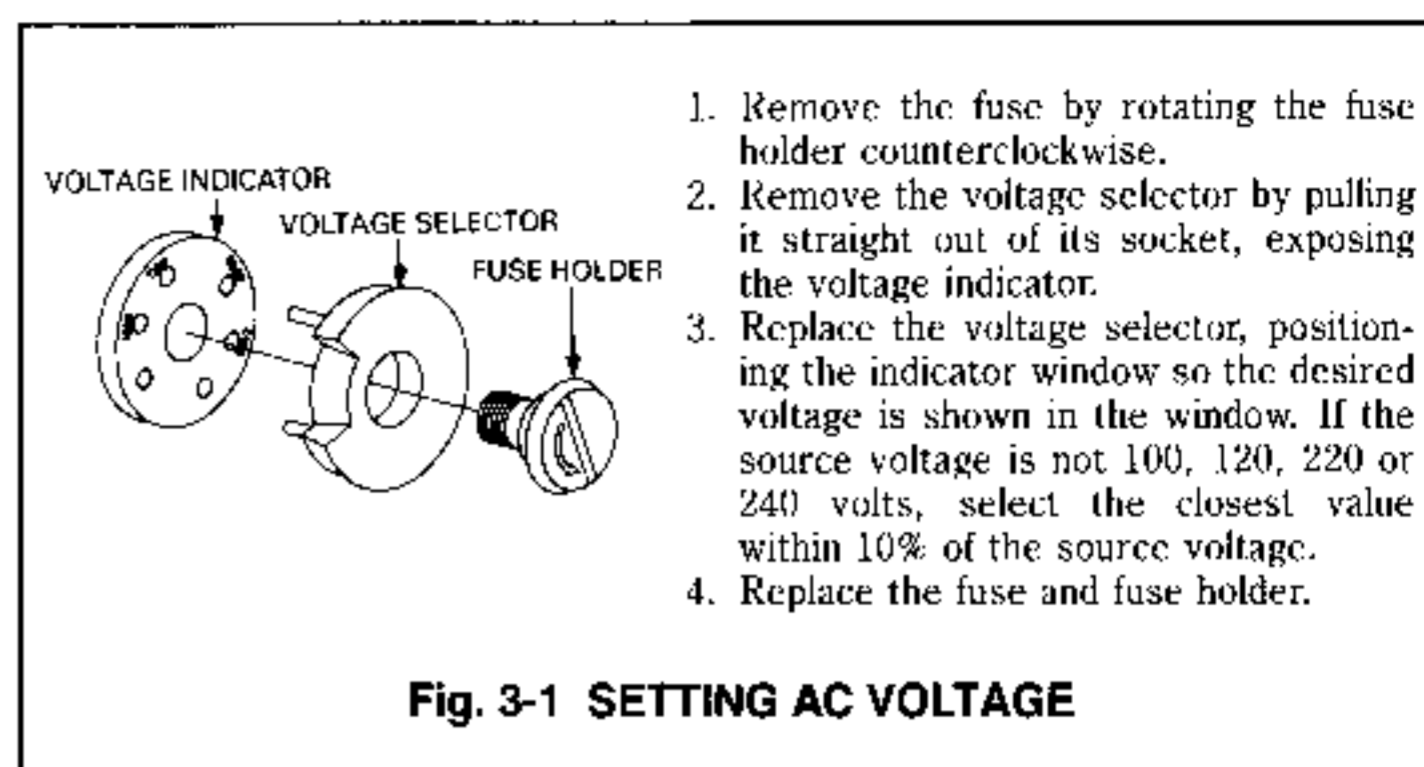

If the NRD-535 is to be run from a DC source, the supplied DC cable may be used by connecting it to the DC power connector on the rear panel.

3.2.4 CONNECTING AN EXTERNAL SPEAKER

The NRD-535 has a built in speaker at the top of the receiver. However, for improved audio quality you may wish to use the optional NVA-319 speaker, or other 4 Ω speaker. Connect the speaker to the EXT-SP jack on the rear panel.

3.2.5 CONNECTING HEADPHONES

To use the optional ST-3 or other 4 to 16 Ω headphones, simply plug them into the PHONES jack on the front panel. Stereo headphones can be used without modification.

SECTION 4: OPERATING CONTROLS

4.1 FRONT PANEL

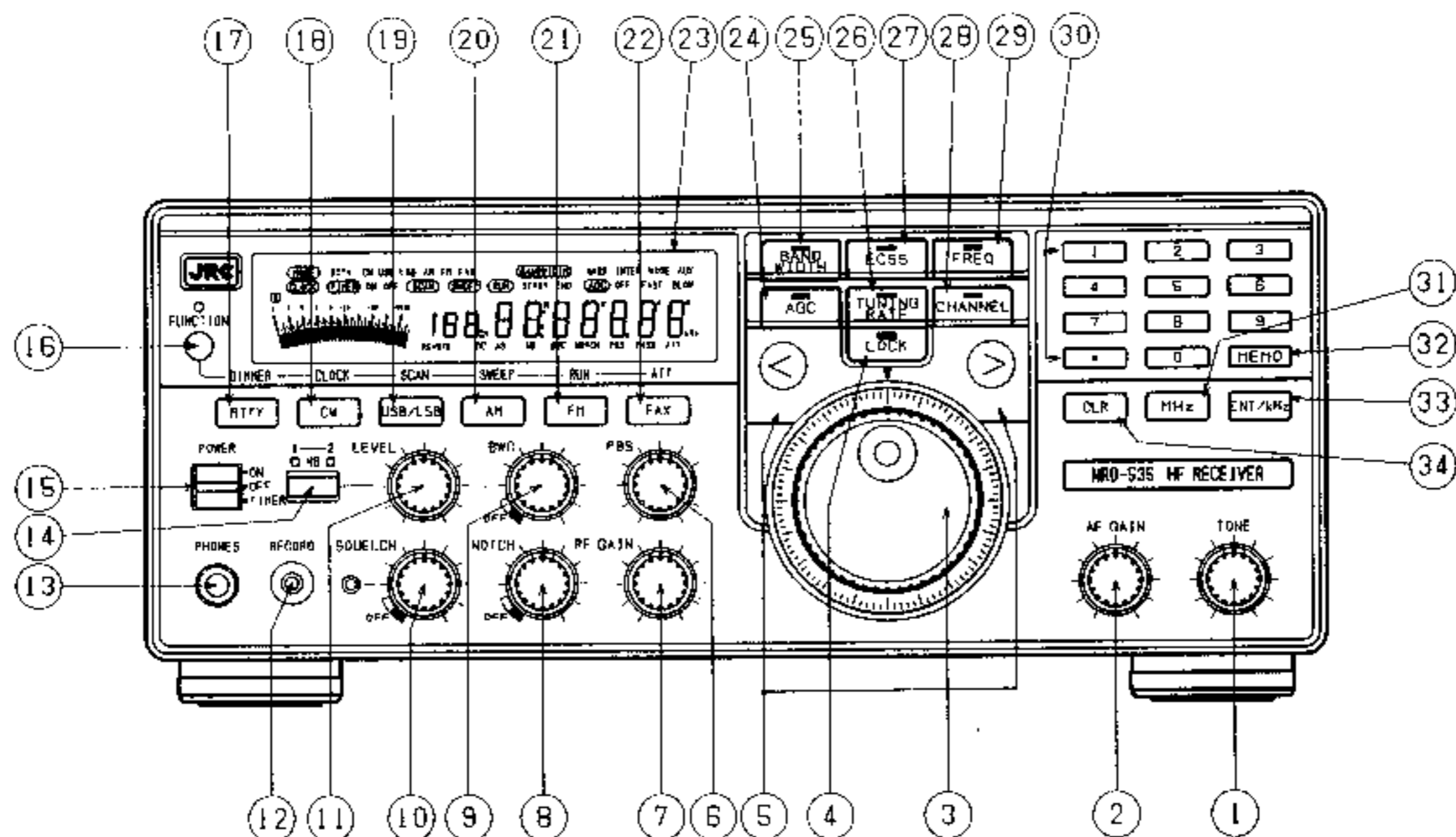

① TONE CONTROL

The TONE control can be used to change the tone quality of the NRD-535's audio heard through the speaker and headphones to the users preference. Clockwise rotation of the control increases the high frequency response.

When the optional RTTY Demodulator (CMH-530) is installed and the RTTY mode is selected, the TONE control will function as a fine tuning control to vary the center frequency of the space filter of the RTTY unit. Normally, the TONE control is set to the mid (12 o'clock) position.

② AF GAIN CONTROL

The AF GAIN control adjusts volume of the speaker and headphone audio. Clockwise rotation increases the volume. This control has no effect on the output level of the LINE OUT or RECORD outputs.

③ MAIN TUNING DIAL

The MAIN TUNING DIAL is used to tune the NRD-535. By rotating the dial, you can change the frequency in steps as small as 1 Hz. Clockwise rotation increases the operating frequency, while counterclockwise rotation decreases the operating frequency.

④ LOCK BUTTON

When the LOCK button is pressed, the MAIN TUNING DIAL be-

comes inoperative to prevent accidental change of frequency. In this case, the button light is illuminated. Only the MAIN TUNING DIAL is disabled; other controls, such as mode buttons and the direct entry keypad will still function normally. To unlock the receiver, simply press the LOCK button again. The light will turn off and the MAIN TUNING DIAL will become operative.

When under external computer control (via the RS-232C Interface), the LOCK button light, as well as the REMOTE indicator on the main display may be illuminated under certain conditions. In this case, the MAIN TUNING DIAL as well as BWC, PBS, NUMERICAL KEYPAD and other buttons and controls will be locked, with the exception of the AF GAIN, RF GAIN, TONE, SQUELCH and NOTCH controls.

⑤ UP/DOWN BUTTON

The UP/DOWN buttons, marked ">" for up and "<" for down, can be used as an alternative method of changing the operating frequency (when FREQ button is lit) or memory channel (when CHANNEL button is lit). Pressing the left or right side will step the frequency or channel number down or up, respectively.

The UP/DOWN button can also be configured by the user to be used in conjunction with the BANDWIDTH, AGC and TUNING RATE buttons (see the descriptions of these buttons in this section for details).

⑥PBS (PASSBAND SHIFT) CONTROL

The PBS control allows the apparent center frequency of the selected IF filter to be adjusted ± 1 kHz, without changing the overall bandwidth of the filter. This allows the user to "move" the filter passband up or down in frequency to combat interference. When the PBS is in operation (not set to 12 o'clock position), the PBS indicator on the main display is illuminated (see Fig. 4-1).

While in the USB mode, the PBS control may be rotated counterclockwise to cut the higher frequency components of the received signal. The reverse is true for the LSB mode. Under normal operation, the PBS control should be set to the 12 o'clock (OFF) position.

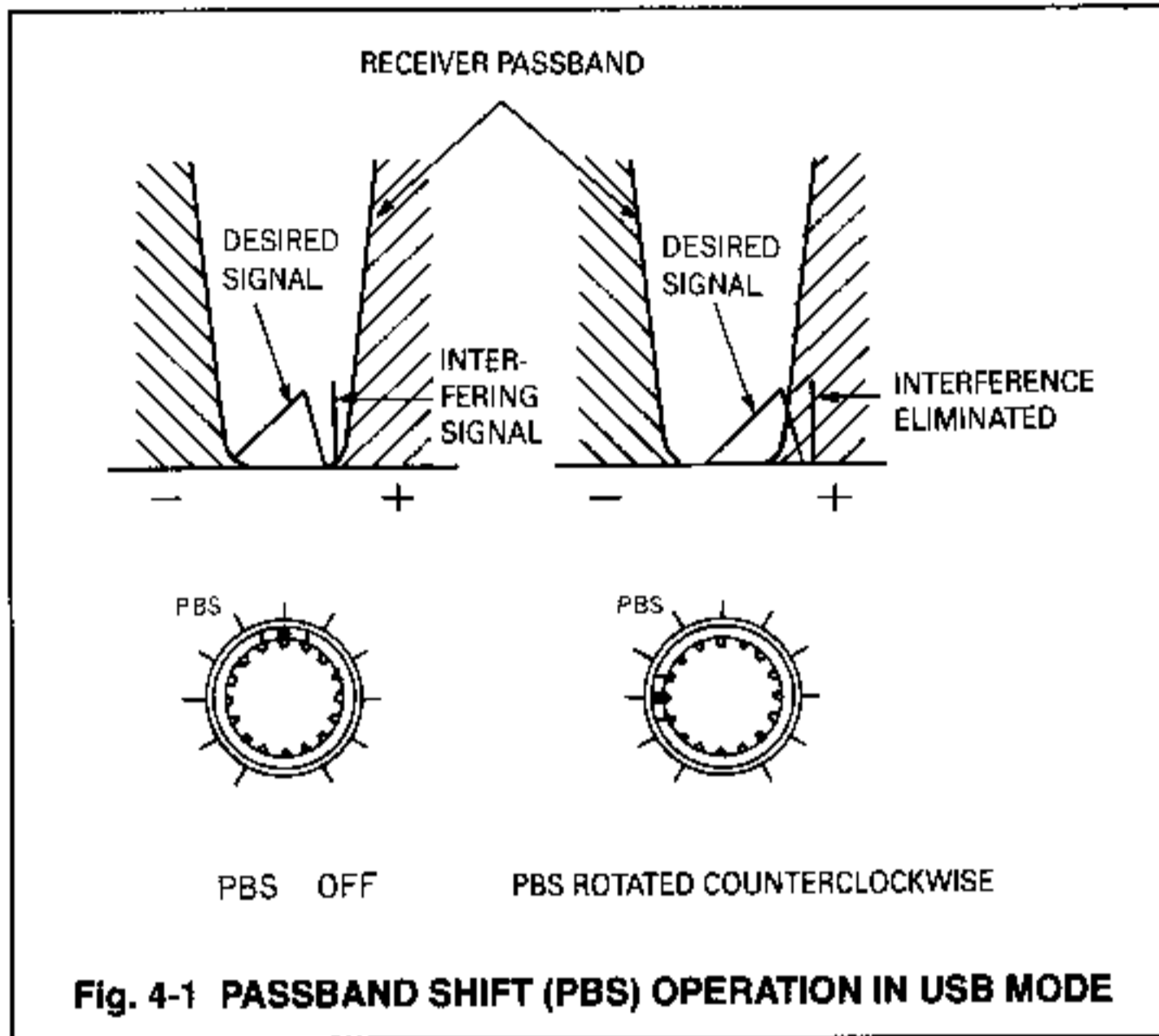

⑦RF GAIN CONTROL

The RF GAIN control allows the gain of the first and second IF amplifiers to be manually adjusted. Maximum gain is achieved when the control is rotated fully clockwise; counterclockwise rotation decreases the gain.

As the gain is gradually decreased, the S-meter begins to deflect. When the S-meter reads S9 the total gain of the first and second IF amplifiers is decreased by approximately 40 dB. If the control is set to the fully counterclockwise position, the S-meter will be fully deflected to indicate a full-scale reading, and no sound will be heard.

Under normal operation, the RF GAIN control will be set for maximum gain. When receiving a relatively strong signal, you may wish to reduce the gain until the background noise level is reduced.

⑧NOTCH CONTROL

The notch filter is used to attenuate a single frequency in the receiver's passband. This is effective to eliminate an interfering carrier or CW signal that is close enough to the operating frequency to be within the passband of the selected filter (see Fig. 4-2).

To activate the notch filter, rotate the NOTCH control clockwise from the OFF position slowly until the offending signal is attenuated. When the notch filter is in operation the NOTCH indicator on the main display is illuminated. When not in use, the NOTCH control should be set to the OFF (fully counterclockwise) position. The notch filter should never be used when receiving in the AM, ECSS-LBS or ECSS-USB modes.

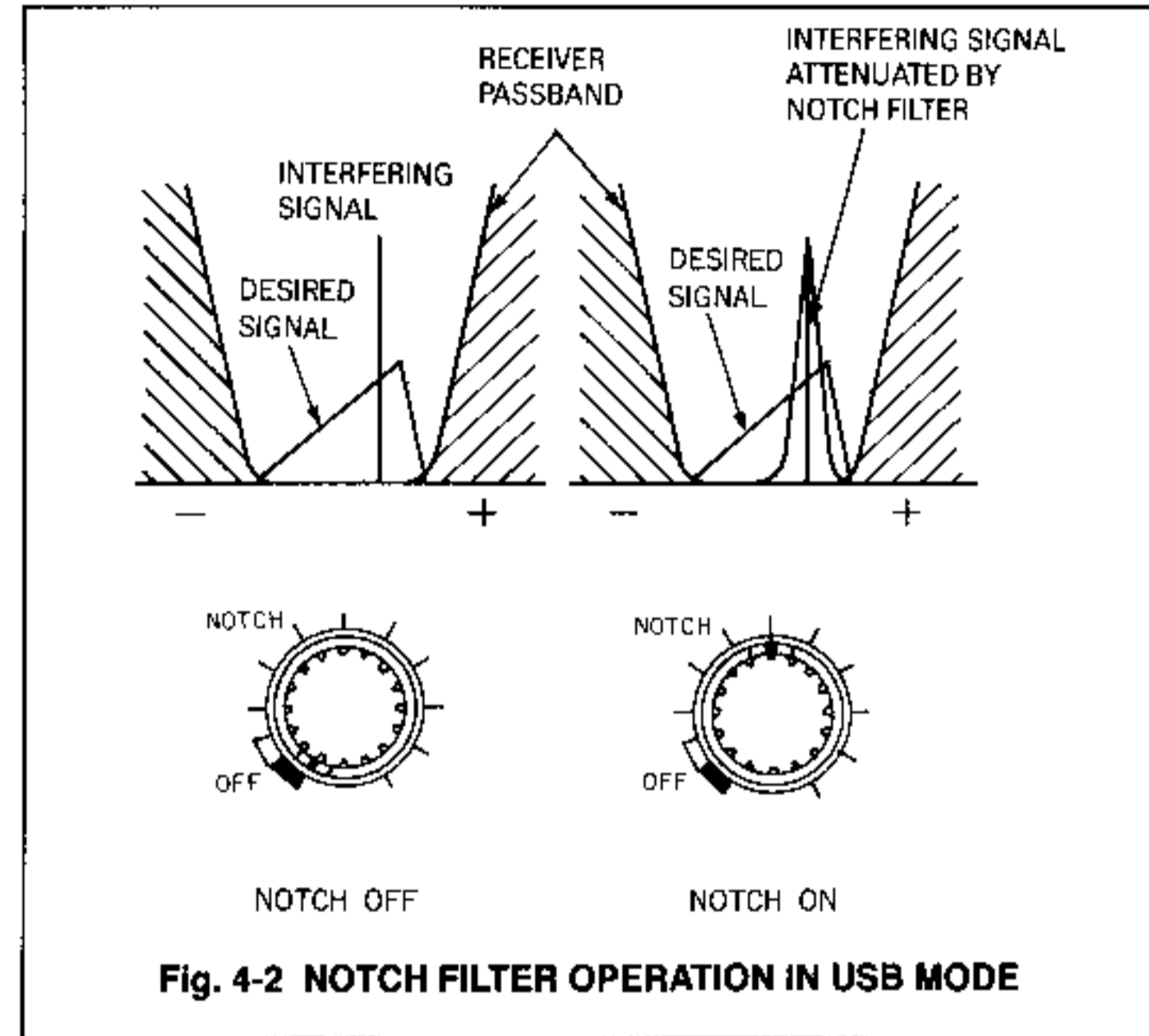

⑨BANDWIDTH CONTROL (BWC)

The BWC can narrow the overall width of the receiver passband continuously from a maximum of 2.4 kHz to a minimum of approximately 500 Hz, without changing the center frequency of the passband (see Fig. 4-3). This feature is only available when the bandwidth is set to INTER, except AM and FM mode.

Clockwise rotation narrows the bandwidth. When not in use, the control should be set to the OFF (fully counterclockwise) position.

The Bandwidth Control Unit (CFL-243) is an optional item except in the case of the NRD-535D Deluxe model receiver, for which it is a standard feature.

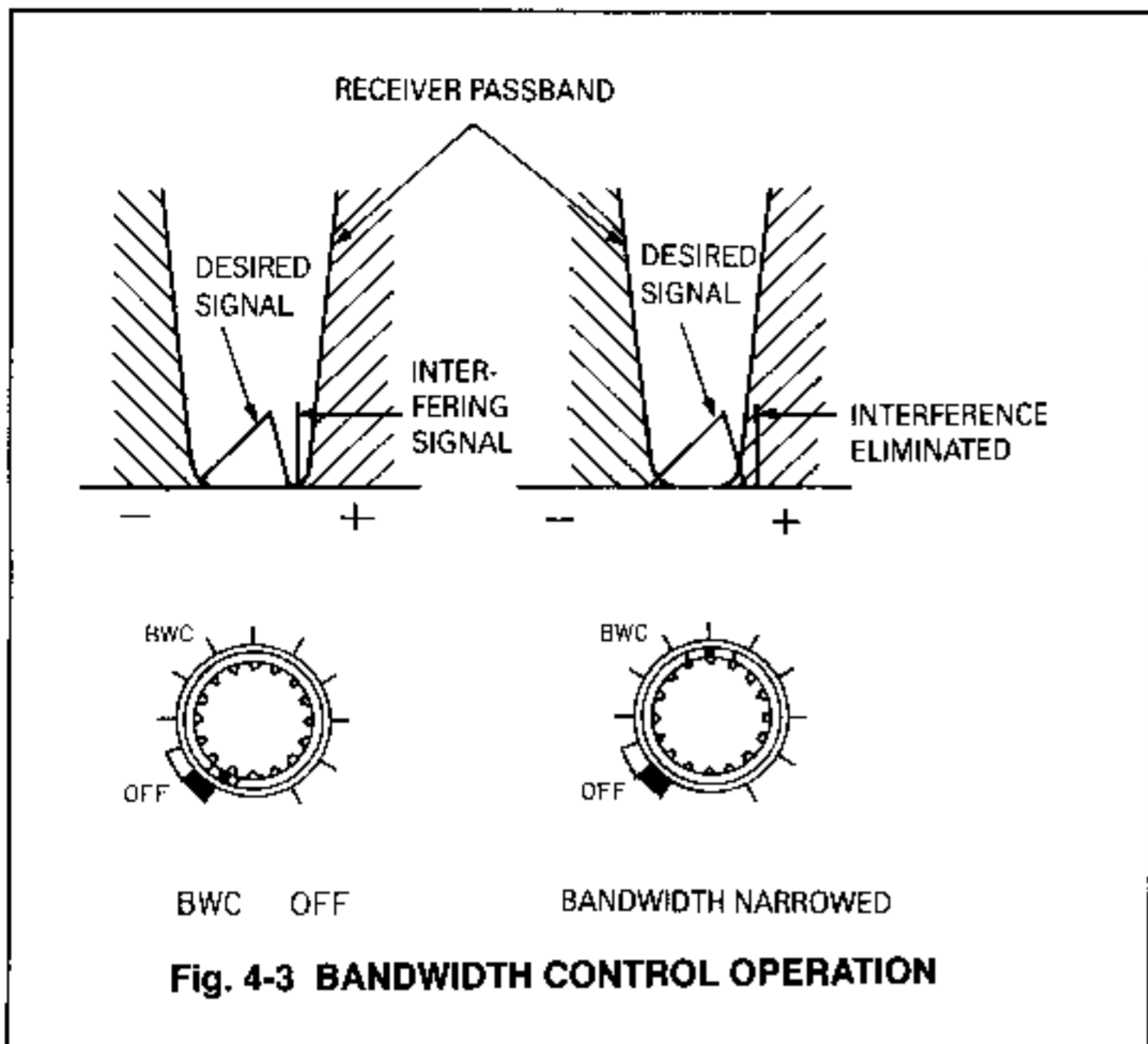

10 SQUELCH CONTROL

The SQUELCH control is used to mute the receiver audio at times of low or no signal. The more clockwise the control is rotated, the stronger the received signal needs to be in order to break the squelch and be heard. When the squelch circuit is in operation the SQUELCH indicator on the main display is illuminated.

Please note that the SQUELCH control can operate in all modes. However, when the AGC is set OFF, the SQUELCH control does not operate, except for the FM mode.

11 NOISE BLANKER (NB) LEVEL CONTROL

The NB LEVEL control sets the blanking level of the noise blanker. To eliminate pulse interference, press the NB button next to the control to select either NB 1 or NB 2, depending on the type of noise (see the description of the NB button in this section details). Then, rotate the control clockwise until the interference is alleviated.

If the NB LEVEL is set too high, distortion to the received signal may occur. Therefore, we recommend the noise blanker be left OFF when it is not needed.

12 RECORD JACK

The RECORD jack is available for connection of a recording device. It is a fixed-level audio output and therefore not affected by the AF GAIN control setting. Output impedance is 600Ω.

13 PHONES JACK

Headphones can be connected to the PHONES jack for private listening. We recommend a set of headphones designed for communications purposes, such as the optional ST-3 headphones. Stereo headphones may be used without modification.

The audio output level of the PHONES jack is controlled by the AF

GAIN control. Also, when headphones are used, the internal (or external) speaker is switched off automatically.

14 NOISE BLANKER (NB) BUTTON

The NB button selects the noise blanker setting: NB 1, NB 2 or OFF. Select NB 1 for ignition type noise from automobiles, etc.; NB 2 is used for suppressing wide-band noise such as “woodpeckers” caused by over the horizon (OTH) radar installations. The blanking level is set by the NB LEVEL control described earlier in this section.

The LEDs above the button indicate the setting; if neither LED is lit, the noise blanker is OFF.

15 POWER/TIMER ON-OFF SWITCH

The POWER/TIMER switch is used to turn the NRD-535 ON or OFF. It can also put the receiver into standby mode for automatic on/off control, as prescribed by the timer settings. For details on setting the timer parameters, see the description of the CW MODE (CLOCK) button in this section.

16 FUNCTION BUTTON

When the FUNCTION button is pressed, the LED above the button is illuminated, and the row of mode selection buttons beneath the main display assume their alternate functions as detailed in the descriptions of each button in this section. To escape from the alternate function mode, simply press the button again.

17 RTTY MODE (DIMMER) BUTTON

Under normal operation, the RTTY button selects the RTTY mode for radioteletype reception. If the optional RTTY Demodulator (CMH-530) is installed, it will also be activated and begin to output received data through the RS-232C Interface port.

If the FUNCTION button is pressed first, the RTTY button controls the DIMMER. Repeated pressing of the button will cycle through the three brightness levels of the display and front panel LEDs.

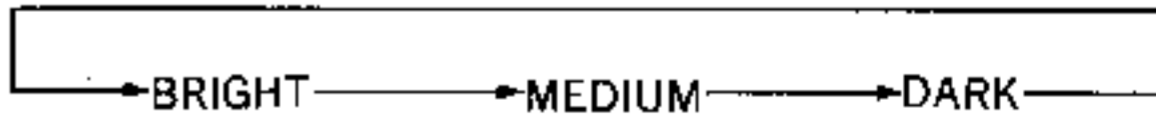

18 CW MODE (CLOCK) BUTTON

Under normal operation, the CW button selects the CW mode for Morse code reception. The BFO is automatically offset according to the User Definition setting No. 3 (see section 5.6 for details; factory default setting is +800 Hz).

If the FUNCTION button is pressed first, the CW button controls the CLOCK functions, including timer settings. Repeated pressing of the button will cycle through the three parameters: clock, timer on and timer off. These parameters can be set and changed by entering the times with the NUMERICAL KEYPAD and pressing the ENT/kHz button.

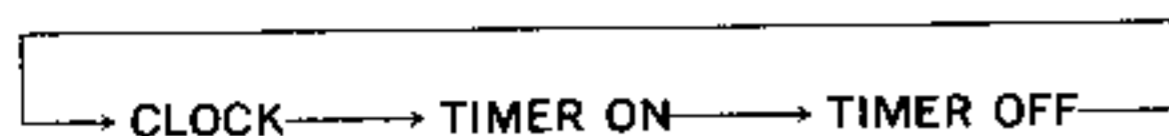

19 USB/LSB (SCAN) BUTTON

Under normal operation, the USB/LSB button selects the Upper Sideband and Lower Sideband modes for SSB voice reception. Repeated pressing of the button will result in switching between the two modes.

If the FUNCTION button is pressed first, the USB/LSB button controls the SCAN parameters. Please refer to section 5.3 for details regarding the NRD-535's scan features.

20 AM (SWEEP) BUTTON

Under normal operation, the AM button selects the Amplitude Modulation mode for receiving shortwave and mediumwave broadcast stations, as well as other AM signals.

If the FUNCTION button is pressed first, the AM button controls the SWEEP parameters. Please refer to section 5.3 for details regarding the NRD-535's sweep features.

21 FM (RUN) BUTTON

Under normal operation, the FM button selects the Frequency Modulation mode for receiving narrowband FM signals, such as 10 meter amateur stations (mostly above 29 MHz).

If the FUNCTION button is pressed first, the FM button controls the RUN function, which starts and stops the SCAN and SWEEP operations. Please refer to section 5.3 for details regarding the NRD-535's scan and sweep features.

22 FAX (ATT) BUTTON

Under normal operation, the FAX button selects the Facsimile mode for receiving weather charts, press photos, etc.

If the FUNCTION button is pressed first, the FAX button turns the ATT (attenuator) on and off. The attenuator should be used if the desired signal is being blocked by a strong adjacent signal, or if you are experiencing intermodulation interference from a powerful local transmitter. When the attenuator is in use, the ATT indicator on the main display is illuminated. The attenuator decreases receiver sensitivity by approximately 20 dB. Therefore, we recommend the attenuator be turned off when it is not needed.

23 FLUORESCENT DISPLAY

The NRD-535's main display panel indicates all vital receiver parameters, as described below.

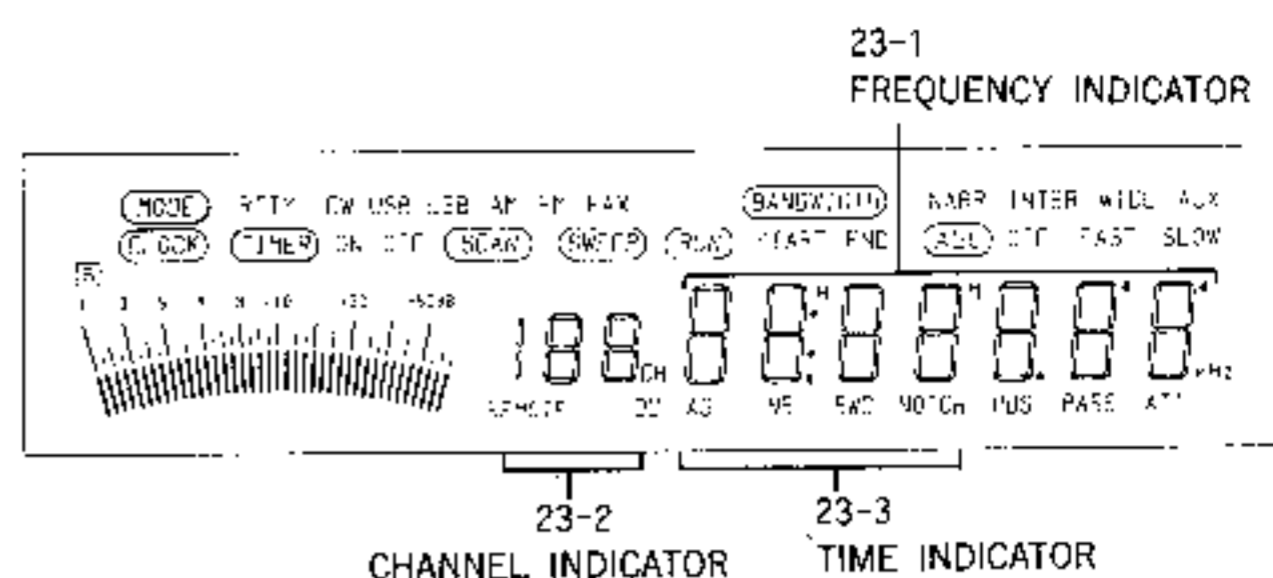

Fig. 4-4 MAIN DISPLAY

FREQUENCY INDICATOR: Displays the current operating frequency (see Fig. 4-4).

CHANNEL INDICATOR: Displays the channel number when CHANNEL button light is illuminated, (see Fig. 4-4).

TIME INDICATOR: Displays the time when in CLOCK mode (see Fig. 4-4).

MODE: The MODE indicator as well as the current receive mode (RTTY, CW, USB, LSB, AM, FM or FAX) will be illuminated on the display. When using ECSS a combination of the AM and USB or LSB will be displayed, depending on the selected sideband.

BANDWIDTH: The BANDWIDTH indicator as well as the selected bandwidth filter (NARR, INTER, WIDE or AUX) will be illuminated on the display, except while in the FM mode.

CLOCK: When the CLOCK indicator is illuminated, the display will show the current time.

TIMER ON: When the TIMER ON indicator is illuminated, the display will show the time that the receiver is programmed to turn on automatically (if receiver is set for timer operation).

TIMER OFF: When the TIMER OFF indicator is illuminated, the display will show the time that the receiver is programmed to turn off automatically (if receiver is set for timer operation).

SCAN START: When the SCAN START indicator is illuminated, the display will show the starting channel number and parameters, as programmed for SCAN operation.

SCAN END: When the SCAN END indicator is illuminated, the display will show the ending channel number and parameters, as programmed for SCAN operation.

SWEEP START: When the SWEEP START indicator is illuminated, the display will show the starting frequency and parameters, as programmed for SWEEP operation.

SWEEP END: When the SWEEP END indicator is illuminated, the display will show the ending frequency and parameters, as programmed for SWEEP operation.

RUN: When illuminated, the RUN indicator shows that the SCAN or SWEEP operation is being performed.

AGC: The AGC indicator as well as the selected AGC setting (OFF, FAST or SLOW) will be illuminated on the display.

S-METER: Indicates the strength of the received signal, and is calibrated in standard "S" units.

REMOTE: When illuminated, the REMOTE indicator shows that the NRD-535's RS-232C Interface is in use.

DC: When illuminated, the DC indicator shows that the receiver is operating from a DC power source.

AS: When illuminated, the AS indicator shows that the Auto-Stop feature is enabled. The receiver will then stop scanning or sweeping whenever the squelch threshold is broken. The receiver will also resume scan or sweep operation automatically when signal stops or drops below the squelch threshold level.

NB: When illuminated, the NB indicator shows that the Noise Blanker is in use.

BWC: When illuminated, the BWC indicator shows that the Bandwidth Control is in use.

NOTCH: When illuminated, the NOTCH indicator shows that the Notch Filter is in use.

PBS: When illuminated, the PBS indicator shows that the Passband Shift control is in use.

PASS: When illuminated, the PASS indicator shows that the input tuning circuit is bypassed.

ATT: When illuminated, the ATT indicator shows that the attenuator is in use.

24 AGC BUTTON

The AGC button is used to select the time constant of the Automatic Gain Control (FAST or SLOW) or disable the AGC completely (OFF). This button is operable in all modes except FM.

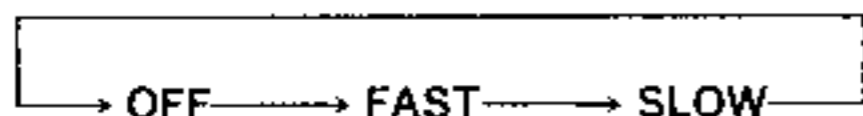

If the jumper resistor RJ 6 mounted on CDC-493AD CPU board is removed, you can select AGC time constant between FAST and SLOW, passing the OFF position. The SLOW setting is often used when receiving a relatively strong signal in the SSB mode. This keeps the gain from changing drastically between voice peaks, and thereby keeps background noise down to a minimum level.

The FAST setting should be used for tuning across a band, or when listening to several stations of various signal levels on a single frequency. The AGC will respond more quickly, so that little or no transmissions are lost while during the AGC "hang" time.

The OFF setting is seldom used, and requires manual setting of the RF GAIN control. There may be times that you wish to do this, but

usually the same result can be achieved by leaving the AGC set to FAST and adjusting the RF GAIN control until the S-meter level reads the same or slightly higher than it does during full-gain reception.

Each time the AGC button is pressed, the receiver steps through the three settings. In addition, you may configure the UP/DOWN buttons to select the AGC settings by pressing the MEMO button and then the AGC button. When the NRD-535 is set for this selection mode, the AGC button light is illuminated. Now, for example, you can switch from SLOW to FAST by pressing the DOWN button, without first stepping through the OFF position. This method of selection remains in effect until you press the MEMO button and then AGC button again.

25 BANDWIDTH BUTTON

The BANDWIDTH button is used to select one of the NRD-535's IF filters (NARR, INTER, WIDE or AUX).

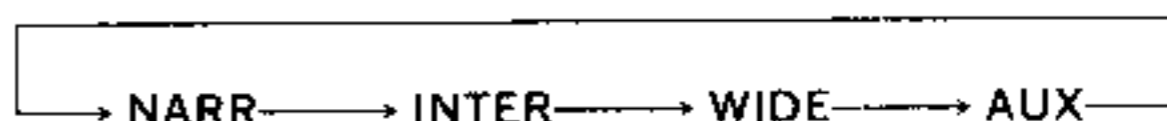

The NARR filter position is inoperable unless an optional crystal filter is installed. You may choose from the following filters:

0.3 kHz (CFL-231) For extra narrow CW and RTTY reception

0.5 kHz (CFL-232) For narrow CW and RTTY reception

1.0 kHz (CFL-233) For wide CW, RTTY and FAX reception

1.8 kHz (CFL-218A) For narrow SSB reception

2.4 kHz (CFL-251) For wide SSB reception

In the case of the NRD-535D Deluxe model, the CFL-233 1.0 kHz filter is installed in the NARR position as standard equipment. If you wish, you may change this filter at any time to one of the above filters.

The INTER filter is 2.0 kHz wide, and is ideal for SSB reception. With the Bandwidth Control Unit (CFL-243) installed, the INTER filter can be narrowed continuously down to approximately 0.5 kHz (BWC Unit is standard equipment on the NRD-535D Deluxe model). This enables the INTER filter to be used for narrowband CW, RTTY and FAX reception.

The WIDE filter is 6.0 kHz wide, and is intended to be used for AM broadcast reception on the shortwave and mediumwave bands.

The AUX position is available for adding an additional optional crystal filter (see list of choices above, under description of NARR filter). If no filter is installed, the default bandwidth of 12 kHz is selected.

Each time the BANDWIDTH button is pressed, the receiver steps through the four filters. In addition, you may configure the UP/DOWN buttons to select the IF filter by pressing the MEMO button and then the BANDWIDTH button. When the NRD-535 is set for this selection mode, the BANDWIDTH button light is illuminated. Now, for example, you can switch from WIDE to INTER by pressing the DOWN button once, without first stepping through the AUX and NARR positions. This method of selection remains in effect until you press the MEMO button and then BANDWIDTH button again.

26 TUNING RATE BUTTON

The TUNING RATE button is used to select the increments by which the MAIN TUNING DIAL and UP/DOWN buttons change the frequency.

If the ◀ mark appears at the upper right hand corner of the 10 Hz or 100 Hz digit of the frequency display, then that digit represents the selected tuning rate of the MAIN TUNING DIAL. If the ◀ mark is not visible, the selected tuning rate of the MAIN TUNING DIAL is 1 Hz. In this case, the display does not show the 1 Hz digit, although the radio is now capable of tuning in 1 Hz increments.

The UP/DOWN buttons always tune in increments ten times that of the MAIN TUNING DIAL. For example, if the ◀ mark indicates a 100 Hz tuning rate for the MAIN TUNING DIAL, then the UP/DOWN buttons will step the frequency up or down in 1 kHz increments. Likewise, if the ◀ mark is not visible, the UP/DOWN buttons will step the frequency up or down in 10 Hz increments.

Pressing the TUNING RATE button repeatedly will step through the three choices of tuning increments. In addition, you may configure the UP/DOWN buttons to select the tuning rate by pressing the MEMO button and then the TUNING RATE button. When the NRD-535 is set for this selection mode, the TUNING RATE button light is illuminated. Now, for example, you can switch from 100 Hz to 10 Hz increments by pressing the UP button once. This method of selection remains in effect until you press the MEMO button and then TUNING RATE button again.

27 ECSS BUTTON

The ECSS button is used to activate the Exalted Carrier Selectable Sideband (ECSS) Unit (CMF-78), and choose the preferred sideband of the received AM signal. Although a similar procedure is possible by tuning an AM signal in one of the SSB modes, exact tuning is critical and often impossible. The ECSS Unit eliminates the need for exactly zero-beating the received carrier.

To improve the reception of standard AM (double sideband with carrier) signals, such as shortwave and mediumwave broadcast stations, the ECSS unit automatically phase-locks the received signal's carrier and generates a synchronous carrier to match it. This eliminates carrier distortion and reduces the effects of fading. By selecting the sideband with the better quality, adjacent channel interference is reduced or eliminated as well.

To engage ECSS operation, select the AM mode, tune the receiver to within 500 Hz of the desired signal's carrier frequency, and then press the ECSS button. The button light will then be illuminated. Pressing the ECSS button once will select the upper sideband (the AM and USB indicators on the display will be illuminated). Press the ECSS button again to select the lower sideband (the AM and LSB indicators on the display will be illuminated). Press the ECSS button once again to

turn the ECSS circuit off and return to normal AM mode. You may also return to normal AM reception at any time by simply pressing the AM button. Always make sure that the PBS control is set to center position, and the NOTCH control is set to the OFF position.

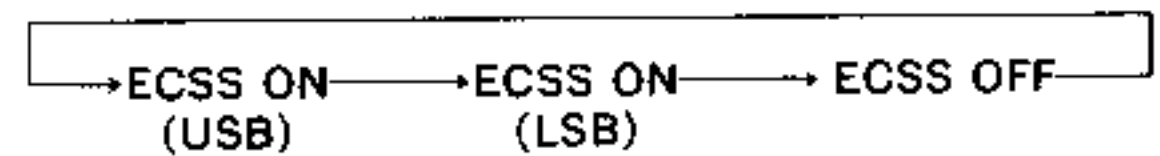

If the ECSS Unit is in use and the NRD-535 is detuned more than 1 kHz, the ECSS will be disengaged automatically.

Use of the ECSS Unit may not always be appropriate, especially if the signal is very weak or if there is more than one carrier within the receiver's IF filter passband (for example: If you are trying to receive Radio Ulan Bator in Mongolia on 4831 kHz and Radio Reloj in Costa Rica is broadcasting on 4832 kHz). Also, during deep signal fades the ECSS Unit may lose lock on the carrier and cause a loud howl. However, reception of most medium to strong signals will be greatly improved when using ECSS.

28 CHANNEL BUTTON

When the CHANNEL button is pressed and the button light is illuminated, you may choose any of the NRD-535's 200 memory channels by entering the channel number directly with the numerical keypad and pressing ENT/kHz. The UP/DOWN buttons can also be used to step up and down through the memory channels. Please refer to section 5.2 for more details on memory operations.

29 FREQ (FREQUENCY) BUTTON

When the FREQ button is pressed and the button light is illuminated, you may enter the desired frequency directly with the numerical keypad. The UP/DOWN buttons can also be used to tune up and down in frequency. Please refer to section 5.1.2 for more details on direct frequency entry.

Normally, a frequency selected during the CHANNEL mode remains on the display after this switch is pressed.

However, if the jumper resistor RJ5 mounted on CDC-493AD CPU board is removed, previously designated frequency during the FREQ mode appears again on the display after this switch is pressed.

30 NUMERICAL KEYPAD

The NUMERICAL KEYPAD is used to input frequency, channel number, clock/timer settings, and other parameters.

31 MHz BUTTON

The MHz button is used when entering the operating frequency in MHz format.

32 MEMO BUTTON

The MEMO button is used in conjunction with the ENT/kHz button to store data in a selected memory channel. It is also used to enter User Definition mode (see section 5.6).

33 ENT/kHz BUTTON

The ENT/kHz button is pressed to enter the frequency or channel after the numerical data has been entered (via NUMERIC KEYPAD).

34 CLR (CLEAR) BUTTON

The CLR button cancels the frequency or channel direct-entry operation if pressed before the ENT/kHz button. Use this button if you make a mistake while entering frequency or channel data with the NUMERIC KEYPAD. The receiver will revert to its previous settings and let you try again.

4.2 REAR PANEL

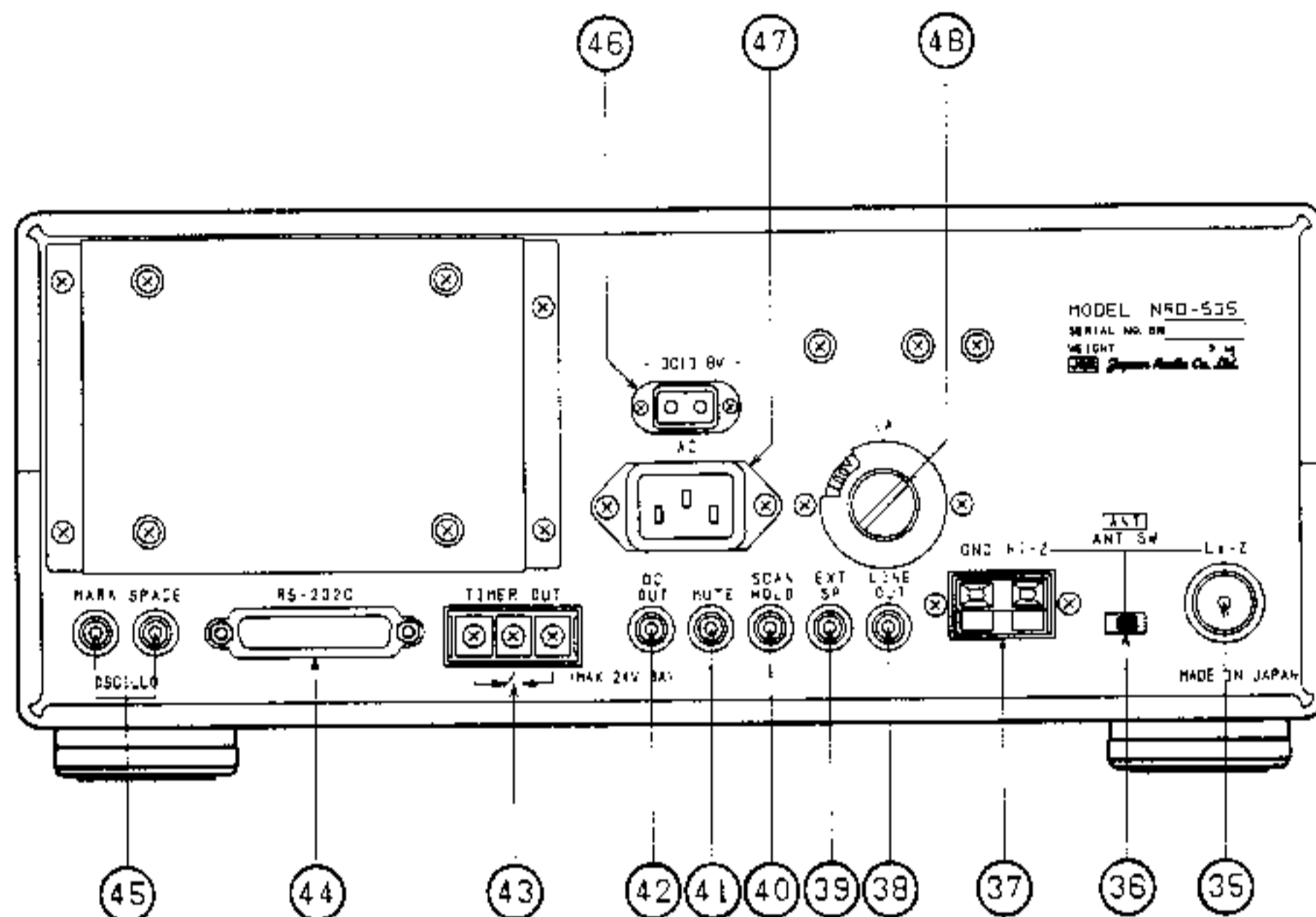

35 ANT Lo-Z (LOW IMPEDANCE ANTENNA) CONNECTOR

An antenna of low (50Ω) impedance can be connected to the ANT Lo-Z connector by using a standard PL-259 coaxial connector. There are many good commercially available passive and active antennas in this category. Please contact your dealer, who can help you decide on the best antenna for your location and needs.

36 ANT SWITCH

The ANT switch is used to select between high and low impedance antenna inputs.

37 ANT HI-Z (HIGH IMPEDANCE ANTENNA) CONNECTOR

An antenna of high impedance (300Ω or more), such as a random length inverted-L, can be connected to the ANT HI-Z connector. An external antenna tuner may be required to provide proper impedance matching.

38 LINE OUT JACK

The LINE OUT jack provides the same fixed level audio output signal as the RECORD jack on the front panel.

39 EXT SP (SPEAKER) JACK

An external speaker, such as the optional NVA-319, can be connected to the EXT SP jack. The output level is controlled by the AF GAIN control on the front panel. When an external speaker is used, the NRD-535's internal speaker is automatically switched off.

40 SCAN HOLD JACK

The SCAN HOLD jack, when grounded, will temporarily pause the scan or sweep operation.

41 MUTE JACK

The MUTE jack can be used to disable the receiver when using the NRD-535 with a transmitter or transceiver. When grounded, the AF, IF and RF stages are muted, and the 20 dB attenuator is activated to provide more than 120 dB antenna isolation.

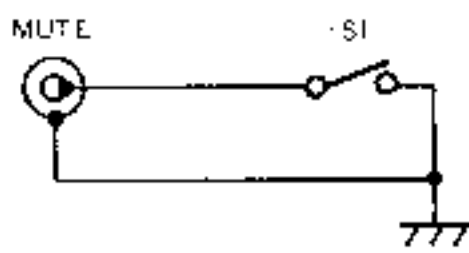

When the S1 is closed (grounded), the NRD-535 is muted.

④②DC OUT JACK

The DC OUT jack provides 10.8 VDC at approximately 30 mA maximum current.

④③TIMER OUT TERMINAL

The TIMER OUT terminal is used in conjunction with the radio's timer for relay control of an external device such as a tape recorder. It can be configured by User Definition No. 1 to be normally on, normally off, or switched on only when squelch threshold is broken. The contact capacity is 24 VDC at 3A maximum.

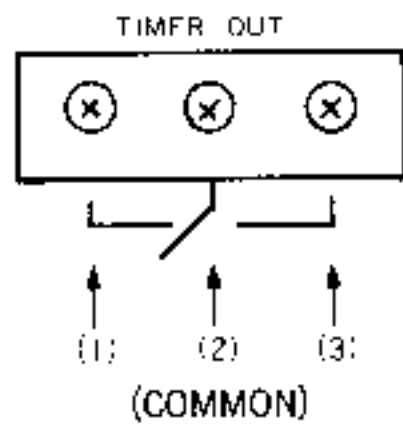

- When the timer is on, relay contacts No. 2 and 3 are connected.
- When the timer is off, contacts No. 1 and 2 are connected.

CAUTION

Never connect an AC power source to the TIMER OUT terminal.

④④RS-232C PORT

The RS-232C port is available for the remote control of the NRD-535 by personal computer (see section 5.5 for details). A commercially available cable that matches the pin wiring configuration detailed in Table 5.1 (in section 5.5) can be used. The NRD-535 end of the cable requires a male DB-25 connector; the connector at the computer end of the cable depends on the computer's serial port specifications. Please contact your dealer for details.

④⑤RTTY MARK/SPACE INDICATOR JACKS

These two jacks provide mark and space output signals for the CKJ-61 RTTY indicator (supplied with CMH-530 RTTY Demodulator).

An oscilloscope can also be used by connecting X-input and Y-input of the scope to the MARK and SPACE jacks.

④⑥DC13.8V (DC POWER) CONNECTOR

To operate the NRD-535 from a DC source, such as a car battery, connect the supplied DC cable to the DC13.8V connector. The other end of the DC cable should be connected to the appropriate positive and negative terminals of the DC source.

If a DC cable other than the one supplied with the radio is to be used, please be sure to insert a 3A fuse in the positive line in order to protect the receiver.

④⑦AC POWER CONNECTOR

To operate the NRD-535 from an AC source, connect the supplied AC power cable to the AC connector.

Please refer to section 3.2.3 to determine if the proper voltage is selected. If the voltage indicator matches the voltage of the AC source, the cable can be plugged into the AC output.

④⑧AC FUSE AND VOLTAGE SELECTOR

The AC fuse is accessible by removing the fuse holder. AC operating voltage can be set by changing the position of the VOLTAGE SELECTOR. For details, please refer to section 3.2.3.

SECTION 5: OPERATING THE NRD-535

5.1 RECEIVING DIFFERENT TYPES OF SIGNALS

The following sections describe the basics of receiving signals in all of the NRD-535's modes.

5.1.1 PRELIMINARY SETTINGS

After all antenna and power connections have been made (as shown in Fig. 3-2), set the POWER switch to ON and set the receiver controls as described below.

LOCK button	OFF
AF GAIN control	Full counterclockwise position
RF GAIN control	Full clockwise position
TONE control	Mid position
NOTCH control	Full counterclockwise position
SQUELCH control	Full counterclockwise position
PBS control	Mid position
NB LEVEL control	Full counterclockwise position
BWC control	Full counterclockwise position
ATT button	OFF

5.1.2 SETTING THE FREQUENCY

There are three different ways to set the frequency of the NRD-535:

• Method 1: Using the MAIN TUNING DIAL

The MAIN TUNING DIAL is capable of tuning in 100 Hz, 10 Hz and 1 Hz increments (the 1 Hz digit is never displayed). While tuning in 100 Hz steps, the 10 Hz digit will be automatically set to zero. Likewise, when tuning in 10 Hz steps, the 1 Hz digit, although not shown, will be automatically set to zero. In practical use, the MAIN TUNING DIAL is used for changing frequencies within a single 1 MHz band.

• Method 2: Using the UP/DOWN buttons

After pressing the FREQ button (or if the FREQ button light is already lit), you may use the UP [>] and DOWN [<] buttons to change frequency. The tuning rate will always be 10 times that of the current MAIN TUNING DIAL tuning rate. This method is for tuning across a wider frequency range at a faster rate than the MAIN TUNING DIAL allows.

• Method 3: Using the NUMERICAL KEYPAD

The desired operating frequency can be entered directly, in MHz or kHz, by using the NUMERICAL KEYPAD. The FREQ button must be pressed or lit before you can use the keypad for frequency entry.

To enter a frequency of 12.3456 MHz, you can enter as:

1 2 3 4 5 . 6 ENT/kHz

or you can enter as:

1 2 . 3 4 5 6 MHz

The 1 Hz digit can not be entered with the keypad.

If you begin to enter a frequency and press a wrong button, you can press the CLR button to cancel the operation and start over.

Choose any of these three tuning methods according to your personal preference.

5.1.3 RECEIVING SSB SIGNALS

In addition to the settings described in section 5.1.1, set the following controls as described below:

USB/LSB button	Press to select USB or LSB mode
BANDWIDTH button	Press to select INTER filter
AGC button	Press to set to SLOW
AF GAIN control	Set to desired volume

Tune to the desired frequency using one of the three methods described in section 5.1.2. To fine tune the signal, rotate the MAIN TUNING DIAL until the SSB signal is clearly heard. The display indicates the frequency of the suppressed carrier.

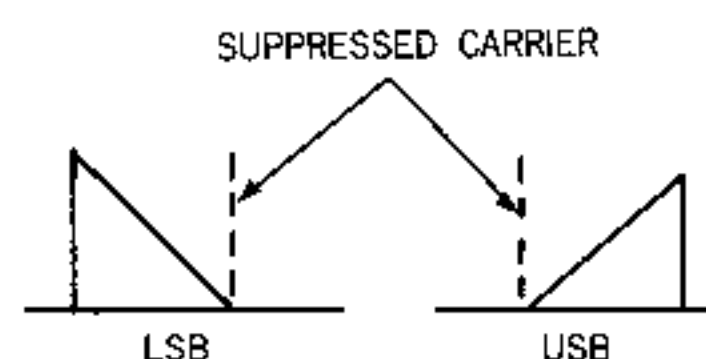

Fig. 5-1 SSB SIGNAL

Reception quality may be improved by using NOTCH, BWC, PBS and other controls as described in section 4.

5.1.4 RECEIVING CW SIGNALS

In addition to the settings described in section 5.1.1, set the following controls as described below:

CW button	Press to select CW mode
BANDWIDTH button	Press to select INTER filter
AGC button	Press to set to FAST
AF GAIN control	Set to desired volume

Tune to the desired frequency using one of the three methods described in section 5.1.2. To fine tune the signal, rotate the MAIN TUNING DIAL until the CW signal is clearly heard, and the demodulated tone is equal to the prescribed offset frequency.

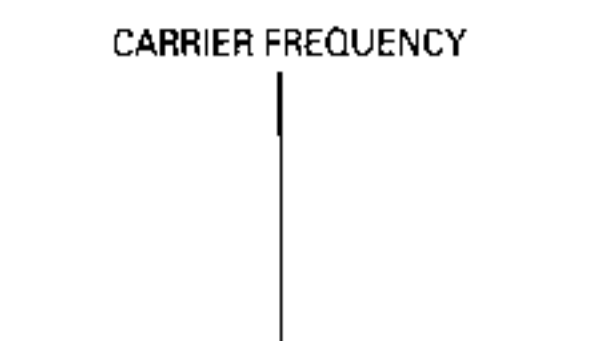

Fig. 5-2 CW SIGNAL

The default CW offset is +800 Hz. However, it may be changed to your preference by setting User Definition No. 3 to any value from -5000 Hz to +5000 Hz.

Reception quality may be improved by using NOTCH, BWC, PBS and other controls as described in section 4. Also, if there is a 1.0 kHz, 0.5 kHz or 0.3 kHz filter installed in the NARR filter position, you may wish to select this filter to reduce interference from adjacent signals.

5.1.5 RECEIVING AM SIGNALS

In addition to the settings described in section 5.1.1, set the following controls as described below:

AM button	Press to select AM mode
BANDWIDTH button	Press to select WIDE filter
AGC button	Press to set to FAST
AF GAIN control	Set to desired volume

Tune to the desired frequency using one of the three methods described in Section 5.1.2. To fine tune the signal, rotate the MAIN TUNING DIAL until the AM signal is clearly heard.

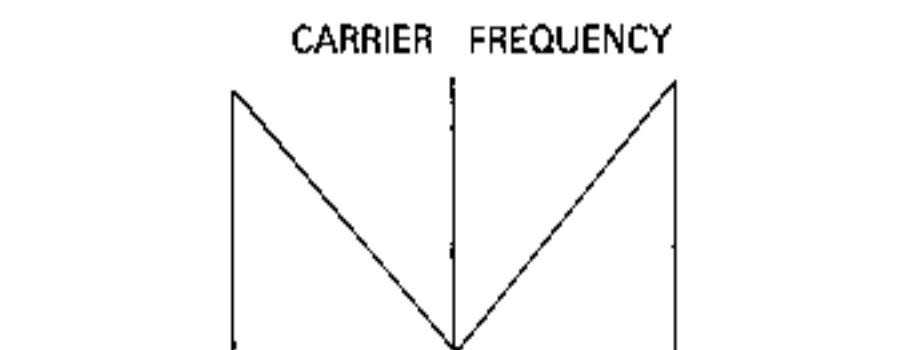

Fig. 5-3 AM SIGNAL

If the received signal is reasonably strong, yet suffers from adjacent channel interference and/or selective fading distortion, reception quality can often be greatly improved by using the ECSS Unit (CMF-78; optional except for NRD-535D Deluxe model). Please refer to section 4, (27) for details of ECSS operation.

5.1.6 RECEIVING RTTY SIGNALS

In addition to the settings described in section 5.1.1, set the following controls as described below:

RTTY button	Press to select RTTY mode
BANDWIDTH button	Press to select INTER filter
AGC button	Press to set to FAST
AF GAIN control	Set to desired volume

Tune to the desired frequency using one of the three methods described in section 5.1.2. To fine tune the signal, rotate the MAIN TUNING DIAL until the RTTY signal is clearly heard. In the RTTY mode, the NRD-535's display will indicate the center frequency (between mark and space frequencies).

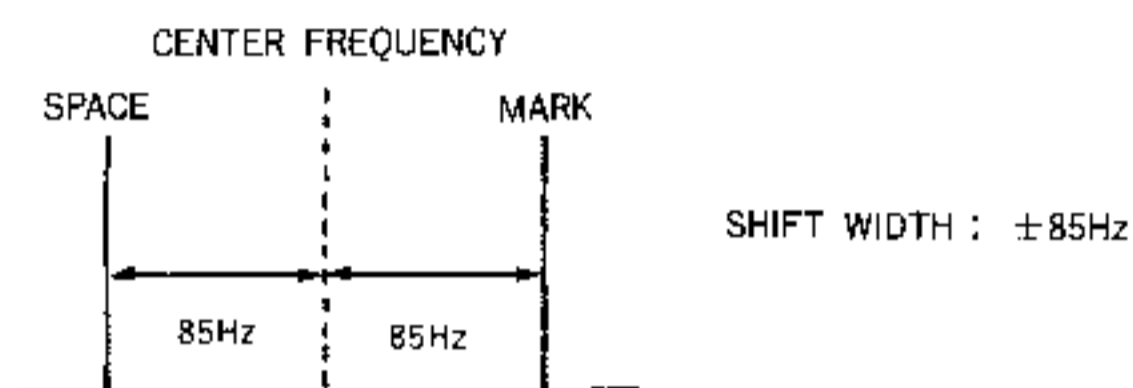

Fig. 5-4 RTTY SIGNAL

The signal should be tuned so that the mark and space frequency indicators on your RTTY demodulator indicate the signal is properly tuned. In the case of the optional RTTY Interface (CMH-530), the MARK and SPACE indicators of the CKJ-61 Indicator Unit (furnished with the CMH-530) will alternately illuminate when the signal is tuned correctly. In common HF use, the mark frequency when produce a 2125 Hz audio tone when demodulated; the space frequency, of course, will depend on the selected shift between mark and space frequencies.

For further details on the operation of the CMH-530 RTTY Demodulator, please refer to section 5.7.

5.1.7 RECEIVING FAX SIGNALS

In addition to the settings described in section 5.1.1, set the following controls as described below:

FAX button	Press to select FAX mode
BANDWIDTH button	Press to select INTER filter
AGC button	Press to set to FAST
AF GAIN control	Set to desired volume

Tune to the desired frequency using one of the three methods described in Section 5.1.2. To fine tune the signal, rotate the MAIN TUNING DIAL until the FAX signal is clearly heard. In the FAX mode, the NRD-535's display will indicate the center frequency (between mark [black] and space [white] frequencies).

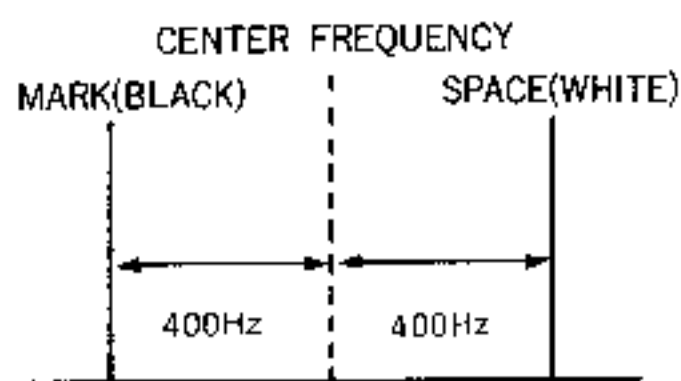

Fig. 5-5 FAX SIGNAL

Many commercially available radio facsimile demodulators are available. Please consult with your dealer to decide which unit best meets your needs.

5.1.8 RECEIVING FM SIGNALS

In addition to the settings described in section 5.1.1, set the following controls as described below:

FM button	Press to select FM mode
AF GAIN control	Set to desired volume

Tune to the desired frequency using one of the three methods described in section 5.1.2. To fine tune the signal, rotate the MAIN TUNING DIAL until the FM signal is clearly heard. In the FM mode, the AGC and BANDWIDTH controls are disabled.

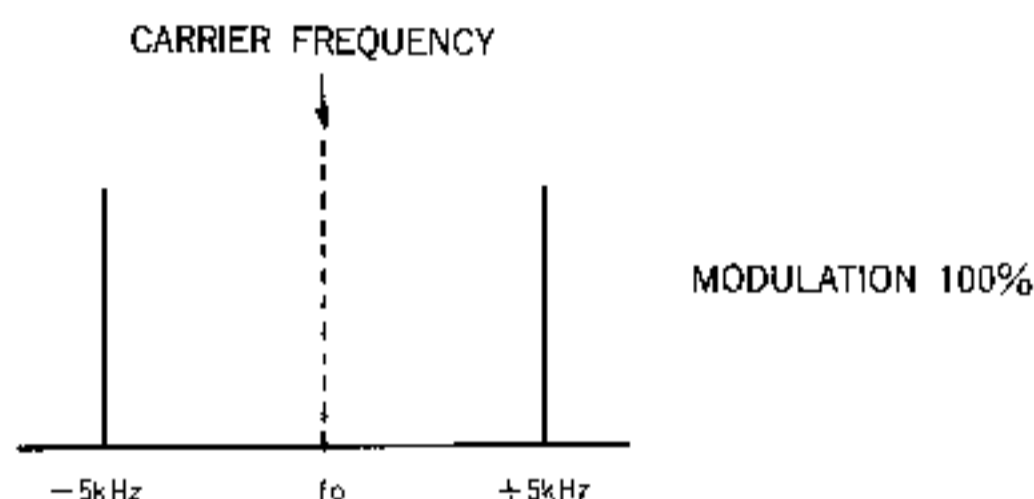

Fig. 5-6 FM SIGNAL

Please note that the NRD-535's FM mode is narrowband FM, and is not intended for receiving broadcast FM stations. The most common use of FM in the HF spectrum is amateur radio FM, generally found above 29 MHz. The maximum deviation in the FM mode is ± 5 kHz.

5.2 MEMORY CHANNEL OPERATIONS

The NRD-535 is capable of storing up to 200 memory channels. Each channel includes frequency, mode, bandwidth, attenuator and AGC settings. If the optional RTTY Demodulator (CMH-530) is installed, you may also store baud rate, shift width and polarity settings if the channel's mode is RTTY. All memory channels are preserved by a lithium back up battery.

5.2.1 SELECTING A MEMORY CHANNEL

There are two methods for selecting a memory channel:

• Method 1: Using the UP/DOWN button

Press the CHANNEL button; the button light should be illuminated.

The UP/DOWN buttons can now be used to step up or down in channel number, until the desired channel is reached.

• Method 2: Using the NUMERICAL KEYPAD

Press the CHANNEL button; the button light should be illuminated. The NUMERICAL KEYPAD can now be used directly enter the desired channel. For example, to select channel number 199, press:

1 9 9 ENT/kHz

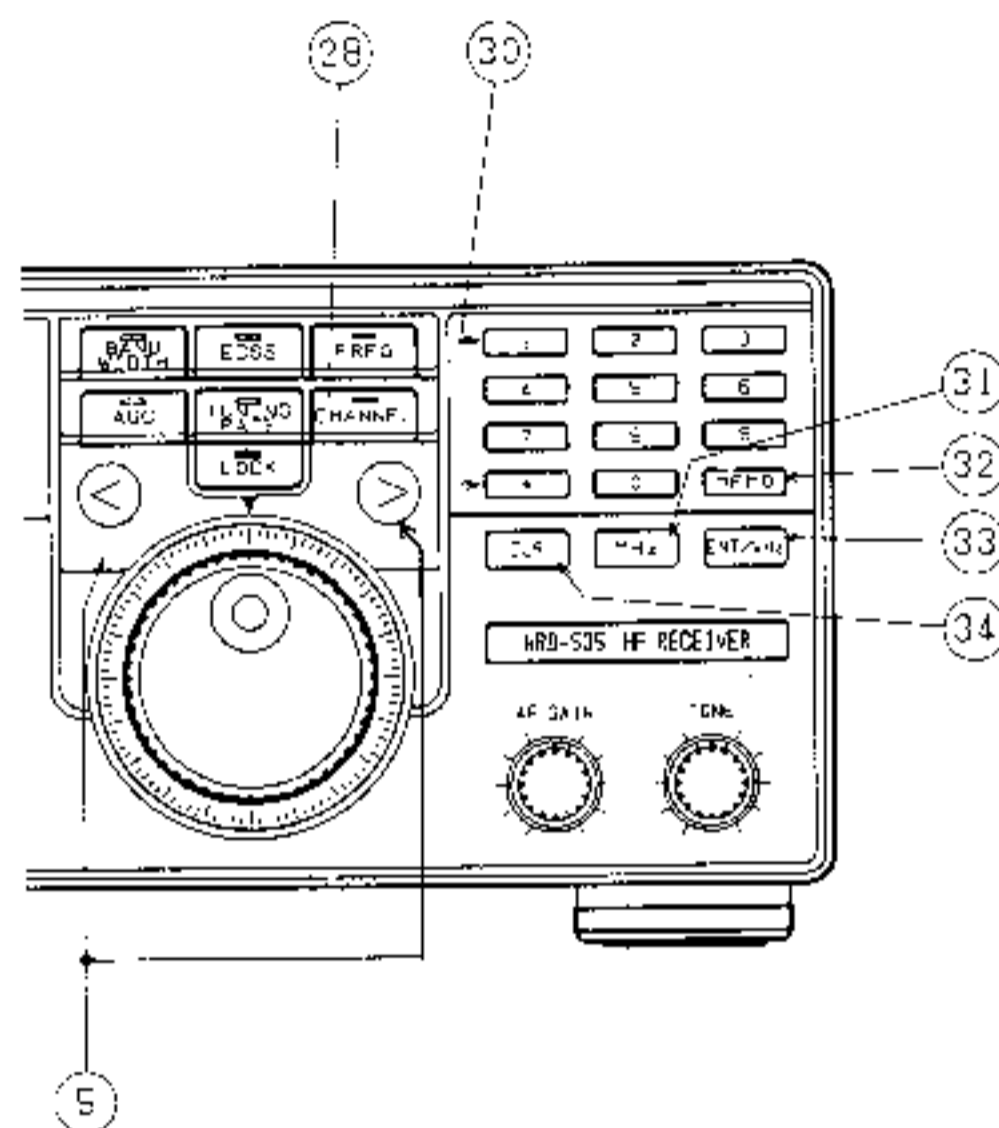

If a channel is selected that does not have any parameters stored to it, the display will show "-----" where the frequency would normally be shown.

5.2.2 STORING INFORMATION TO A MEMORY CHANNEL

After all receiver parameters (frequency, mode, etc.) have been set as described in section 5.1, you may store these settings in a memory channel. First press the MEMO button, then the ENT/kHz button. The channel number segment of the display will blink, prompting you to enter the destination channel number with the NUMERICAL KEYPAD. You may also turn the main tuning dial to review the contents of existing memory channels and to select the destination channel number. After making your channel selection, press the ENT/kHz button again to store the settings. If you wish to cancel this operation, press the FREQ or CHANNEL button before pressing the ENT/kHz button the second time.

For example, to store settings in channel 199, press:

MEMO ENT/kHz 1 9 9 ENT/kHz

5.2.3 ERASING DATA FROM A MEMORY CHANNEL

If you wish to clear a particular memory channel, first press the MEMO button, then the ENT/kHz button. The channel number seg-

ment of the display will blink, prompting you to enter the channel number that you wish to erase. After you do so, press the ENT/kHz button again to clear the settings of the selected channel. If you wish to cancel this operation, press the CHANNEL or FREQ button before pressing the CLR button.

For example, to clear the settings in channel 199, press:

MEMO **ENT/kHz** **1** **9** **9** **CLR**

5.2.4 OPERATING WITH MEMORY CHANNELS

Since the NRD-535's memory channels are tunable, after selecting a channel you may immediately change any of the stored parameters without "dumping" the settings to a VFO. In fact, you might think of the receiver as having 200 VFOs!. If you do change any parameters, however, they are not automatically stored; to save the changes, repeat the steps described in section 5.2.2.

5.3 SCAN AND SWEEP OPERATIONS

The NRD-535's SCAN function can be used to automatically step through consecutive memory channel. The user sets the high and low channel number, as described in section 5.3.1.

The SWEEP function enables the receiver to automatically tune a user-defined frequency range. The user sets the high and low frequencies, as described in section 5.3.2.

If you wish to leave the SCAN or SWEEP mode, simply press the FREQ or CHANNEL button.

During SCAN and SWEEP operations, the PBS, BWC and ECSS controls are disabled.

5.3.1 SETTING THE SCAN START AND SCAN END CHANNELS

The SCAN parameters can be set by first pressing the FUNCTION button and then the USB/LSB (SCAN) button. The receiver's display will alternately show the current start and end channels with each press of this button, as shown by the START and END indicators on the receiver's display. The desired channel number of the start and/or end channel is then entered with the NUMERICAL KEYPAD.

For example, to scan between channels number 55 and 80, enter the following sequence:

FUNCTION **USB/LSB (SCAN)** **5** **5** **ENT/kHz**

Then:

USB/LSB (SCAN) **8** **0** **ENT/kHz**

To begin scanning, press the FM (RUN) button while the FUNCTION button is lit and the receiver is in the SCAN operation mode. The RUN indicator on the main display will be illuminated, while the START

or END indicator will be turned off. To pause the scan operation, press the RUN button again. After pausing, you may continue scanning from the current channel by pressing the RUN button once again. To exit the SCAN mode, simply press the FREQ or CHANNEL button.

5.3.2 SETTING THE SWEEP START AND SWEEP END FREQUENCIES

The SWEEP parameters can be set by first pressing the FUNCTION button and then the AM (SWEEP) button. The receiver's display will alternately show the current START and END frequencies with each press of this button. The desired start and/or end frequency is entered with the NUMERICAL KEYPAD.

For example, to sweep between 15100.0 and 15200.0 kHz, enter the following sequence:

FUNCTION **AM (SWEEP)** **1** **5** **1** **0** **0** **ENT/kHz**

Then:

AM (SWEEP) **1** **5** **2** **0** **0** **ENT/kHz**

To begin sweeping, press the FM (RUN) button while the FUNCTION button is lit and the receiver is in the SWEEP operation mode. The RUN indicator on the main display will be illuminated, while the START or END indicator will be turned off. To pause the sweep operation, press the RUN button again. After pausing, you may continue sweeping from the current frequency by pressing the RUN button once again.

During sweep operations, the receiver will increment the frequency according to the current TUNING RATE settings. You may change TUNING RATE, MODE, AGC and BANDWIDTH settings by as the receiver sweeps. (Remember to turn off the FUNCTION button before trying to change mode!) To exit the SCAN mode, simply press the FREQ or CHANNEL button.

5.3.3 SCAN/SWEEP DELAY PERIOD

The period of time that the receiver remains on each channel or frequency during SCAN and SWEEP operations is manually adjustable. For SCAN, you may select any delay between 0.5 and 5 seconds per channel; for SWEEP, you may select any delay between 0.05 and 0.5 seconds per channel.

User Definition No. 12 is used to set the delay period for scanning, and User Definition No. 13 is used to set the delay period for sweeping (see section 5.6 for further details).

In addition, the delay time may be set while in the RUN operation mode by pressing the UP and DOWN buttons. The display will temporarily show the selected delay time.

5.3.4 AUTO-STOP OPERATION

When the NRD-535's auto stop (AS) feature is enabled, the radio will automatically pause during SCAN or SWEEP operation whenever a signal stronger than the squelch threshold is detected. When the transmission is over, or when the signal strength drops below the squelch threshold, scanning or sweeping resumes automatically.

User Definition No. 15 is used to turn the auto stop feature on and off (see section 5.6 for details). When enabled, the AS indicator on the main display is illuminated.

5.4 CLOCK/TIMER OPERATIONS

The NRD-535 features an internal clock with timer functions that can be used to turn the receiver on and off at preset times. In addition, a timer-controlled relay contact output is available on the rear panel which can be used to control an external device, such as a tape recorder.

To switch to the clock/timer, first press the FUNCTION button and then the CW (CLOCK) button. Repeated pressing of the button will step the display through the CLOCK, TIMER ON and TIMER OFF settings, which will be shown in place of the frequency readout on the main display.

To exit the clock/timer mode and restore the display to the normal frequency readout, simply press the FREQ or CHANNEL button.

The NRD-535's clock does not display the seconds digits as delivered from the factory. By cutting jumper RJ8 on the CPU board (CDC-493AD), the seconds will be added to the displayed time as well as the time output from the "R" computer interface command response.

5.4.1 DISPLAYING AND SETTING THE TIME

Switch to the clock display by pressing the CW (CLOCK) button while the FUNCTION button is lit, until the CLOCK indicator of the main display is illuminated, and the displayed frequency is replaced with the current time.

The current time setting may be changed by entering the new time with the NUMERICAL KEYPAD. For example, to set the clock to 13:23, enter the following sequence:

1 **3** **2** **3** **ENT/kHz**

You may stop the colon mark (:) between the segments of hour and minute on the vacuum fluorescent display from blinking with one-second intervals during the time indication.

For the setting method, refer to Section 5.6 "USER DEFINITIONS". In addition, you may also change so as to display the time data with the digit of the second, which is realized by cutting off the RJ7 of the CPU, CDC-493AD.

5.4.2 SYNCHRONIZING THE CLOCK

The NRD-535's clock can be synchronized to a standard time station (WWV, JJY, etc.). During the time setting procedure described above, pressing the ENT/kHz button at the exact zero seconds interval will set the seconds to 00.

To reset only the seconds, first switch to the CLOCK mode, then press the MEMO button. The colon (:) mark will begin blinking, during which time the ENT/kHz button can be pressed to set the seconds to 00. If between 00 and 29 seconds (for example: 15:45:19), the current minutes reading will not be changed; the clock will be set to 15:45:00. However, if between 30 and 59 seconds (for example: 15:45:39), the minutes reading will be advanced by one, to 15:46:00. To cancel this operation (while the colon is blinking), simply press the MEMO button again.

5.4.3 TIMER OPERATION

Switch to the timer display by pressing the CW (CLOCK) button while the FUNCTION button is lit, until the TIMER ON indicator of the main display is illuminated. You may now set the ON time by using the NUMERICAL KEYPAD, following the same procedure as for the CLOCK time setting (see section 5.4.1). Pressing the CW (CLOCK) button again will illuminate the TIMER OFF indicator; this can also be changed with the NUMERICAL KEYPAD.

After setting the timer parameters, all other receiver parameters (frequency, mode, filter, etc.) may be set as desired. Then set the POWER/TIMER switch to the TIMER position (down) if you wish to enable timer control of the receiver. The main display will show the current time. At the designated TIMER ON time, the receiver will automatically switch on and remain in operation until the TIMER OFF time. At that time the receiver will automatically switch off, and the clock will again be displayed in place of the frequency. The NRD-535 will not operate in the timer mode unless the POWER/TIMER switch is set to the TIMER position.

5.4.4 TIMER OUT RELAY TERMINAL

The TIMER OUT terminal on the rear panel is available for timer-controlled operation of a remote device, such as a tape recorder or preamplifier. Please refer to Fig. 5-7, which illustrates the proper connection of a tape recorder.

Relay contacts No. 2 and 3 are connected when the timer is on. Conversely, contacts No. 1 and 2 are connected when the timer is off (although these conditions can also be changed by User Definition No. 1). A DC voltage (24 VDC, 3A max) may be passed through the relay.

CAUTION

Never connect an AC power source to the TIMER OUT terminal.

D2 <CR> USB
 D3 <CR> LSB
 D4 <CR> AM
 D5 <CR> FM
 D6 <CR> FAX
 D7 <CR> ECSS-USB
 D8 <CR> ECSS-LSB

E WRITE CURRENT RECEIVER STATUS TO CURRENT MEMORY CHANNEL—Dumps current receiver parameters to currently selected channel.

E1 <CR> Write status

See commands, J, K and S for related operations.

F FREQUENCY—Enters desired frequency to receiver VFO.

Emmkkkhhh <CR> mm=MHz
 kkk=kHz
 hhh=Hz

AGC—Sets automatic gain control.

G0 <CR> SLOW
 G1 <CR> FAST
 G2 <CR> OFF

H OPEN/CLOSE RS-232C SERIAL PORT—When receiver is initialized for computer control, the display will indicate REMOTE and all front panel controls except AF GAIN, RF GAIN, POWER and NOTCH will be locked. Turning power off and then on again will reset to normal (serial port closed) operation.

H0 <CR> Closes serial port, unlocks receiver

H1 <CR> Opens serial port, locks receiver

I OUTPUT RECEIVER STATUS—Responds with a string indicating CHANNEL, ATT, BW, MODE, FREQUENCY and AGC settings.

I0 <CR> Output off
 I1 <CR> Output on

Each time any of these parameters are changed, the receiver will send the following string back to the computer.

Iabdfg <CR> a=ATT (0 or 1)
 b=BW (0 to 3)
 d=MODE (0 to 8)
 f=FREQUENCY (mmkkkhhh)
 g=AGC (0 to 2)

J WRITE CURRENT RECEIVER PARAMETERS TO SPECIFIC MEMORY CHANNEL—Dumps current receiver parameters to a specified memory channel (as opposed to the current channel). This command does not affect current receiver settings (in other words, does NOT switch to specified

channel automatically).

Jlccc <CR> ccc=target channel No.
 (000 to 199)

See commands E, K and S for related operations.

K WRITE SPECIFIED RECEIVER PARAMETERS TO SPECIFIED MEMORY CHANNEL—Sends a string that includes parameters for ATT, BW, MODE, FREQUENCY and AGC to a target memory channel without affecting current receiver settings. This operation enables user to set any memory channel while the receiver remains tuned to a single station.

Kcccabdfg <CR> ccc=target channel No.
 (000 to 199)
 a=ATT (0 or 1)
 b=BW (0 to 3)
 d=MODE (0 to 8)
 f=FREQUENCY (mmkkkhhh)
 g=AGC (0 to 2)

See commands E, J and S for related operations.

L READ CHANNEL STATUS—Allows polling of any consecutive group of memory channels.

L <CR> Current channel
 Lsssee <CR> sss=Start channel
 eee=end channel

The receiver will respond by sending back the following strings to the computer for each memory channel polled.

Lcccabdfg <CR> ccc=polled channel No.
 (000 to 199)
 a=ATT (0 or 1)
 b=BW (0 to 3)
 d=MODE (0 to 8)
 f=FREQUENCY (mmkkkhhh)
 g=AGC (0 to 2)

As an example, if channels 001 through 004 were to be polled, the appropriate command would be:

L001004 <CR>

And the response might be:

L001012141905001 <CR>
 L002012213901451 <CR>
 L003014061750001 <CR>
 L004014095800001 <CR>

The data for each channel consist of 17 bytes, including header and terminator. The maximum transfer time for polling all 200 channels is about 7 seconds ($17 \times 200 \times 10 / 4800 = 7.083$ secs.). If a vacant channel is included between the start and end channel, only the channel number and the letter "V" is returned for that channel (i.e., L00V <CR>).

M S METER—This command will respond with a reading of the AGC level which corresponds to the actual S Meter reading.

M <CR> (no parameters)

The response will be a number in the range of 000 to 255, in the following format:

Mnnn <CR> nnn=000 to 255

The actual digital S Meter on the NRD-535 consists of only 40 segments. The following chart shows the relationship between various readings and S-unit measurements:

OUTPUT DATA S-UNIT

OUTPUT DATA	S-UNIT
118	5
106	7
100	9
93	+10 dB
81	+30 dB
72	+50 dB

N NOISE BLANKER—Turns on and selects width of the dual-width Noise Blanker.

N0 <CR> NB off
 N1 <CR> NB 1 on
 N2 <CR> NB 2 on

O TIMER RELAY CONTROL—Useful for controlling external tape recorders that utilize REMOTE start/stop control.

O0 <CR> Relay off
 O1 <CR> Relay on

See command U0 for related operations.

P PASSBAND SHIFT (PBS) CONTROL—Adjusts the setting of the PBS control, shifting apparent IF up or down a maximum of 2 kHz from center frequency.

Psnnn <CR> s="+" or "-" sign
 nnnn=PBS offset in Hz
 (0000 to 2000)

Q READ SQUELCH STATUS—Checks current status of squelch.

Q <CR> (no parameters)

The possible responses to the Q command:

Q0 <CR> Squelch off
 Q1 <CR> Squelch on, receiver muted

R REAL TIME CLOCK (RTC)—Allows user to read time from receiver's internal clock, or to set that clock from computer.

R0 <CR> RTC read
 R1 <CR> RTC set
 R2 <CR> Timer ON set
 R3 <CR> Timer OFF set

R4 <CR> Display clock
 R5 <CR> Display timer ON settings
 R6 <CR> Display timer OFF settings
 R7 <CR> Return to normal frequency display

Response to R0 command:

Rhhmmss <CR> hh=hour (00 to 23)
 mm=minutes (00 to 59)
 ss=seconds (00 to 59)

S SET SPECIFIED CHANNEL AND UPDATE VFO—Differs from "K" command in that this command changes current receiver parameters to those of the target memory channel.

Scccabdfg <CR> ccc=target channel No.(000 to 199)
 a=ATT (0 or 1)
 b=BW (0 to 3)
 d=MODE (0 to 8)
 f=FREQUENCY (mmkkkhhh)
 g=AGC (0 to 2)

See commands E, K and J for related operations.

T 10.8 VDC OUTPUT—Switches DC OUT jack on rear panel on and off.

T0 <CR> OFF
 T1 <CR> ON

U USER DEFINITION SETTINGS—The following 10 commands allow the user to preset the NRD-535's user definition functions, which are described in detail in the manual.

U0 RELAY MODE—Selects timer relay operation as described below.

U00 <CR> No operation when switch is ON (default)
 U01 <CR> Active operation when switch ON
 U02 <CR> Carrier operated relay (COR) operation,

See command O for related operations.

U1 VBT BYPASS—Allows bypassing of front-end variable band-pass tuning (VBT) filter. This may cancel a small amount of attenuation of incoming signals, but may also increase the likelihood of interference from strong out-of-band signals. We recommend that this feature NOT be used except in special circumstances, and that the software program automatically switch the filter back in-line before ending the computer control session.

U10 <CR> VBT bypass off (default)
 U11 <CR> VBT bypass on

U2 BFO PITCH—Adjusts beat note offset from carrier frequency during CW operation.

U2snnnn <CR> s="+" or "-" sign
 nnnn=offset in Hz (0000 to 5000)

For example:

U2+0800 <CR> +800 Hz BFO offset (default)

U3 RTTY PARAMETER SETTINGS—Controls the optional CMH-530 RTTY Demodulator's baud rate, shift width and polarity.

U3brsp <CR> br=baud rate divided (00 to 99; see below)
 s=shift width (0 to 2; see below)
 p=polarity (0 or 1; see below)

• BAUD RATE—The "br" divider is used in the following equation to determine the demodulator's speed setting:

$$\text{Baud rate} = 75000 \div 1\text{br}0$$

Therefore, if "br"=65:

$$\text{Baud rate} = 75000 \div 1650 = 45.45$$

For 50 baud, "br" would be 50, so:

$$\text{Baud rate} = 75000 \div 1500 = 50$$

And for 75 baud, "br" would be 00, so:

$$\text{Baud rate} = 75000 \div 1000 = 75$$

• SHIFT WIDTH—Three widths are selectable as follows:

170 Hz s=0
 400 Hz s=1
 850 Hz s=2

• POLARITY—Normal and Reverse polarity is selectable as follows:

Normal p=0
 Reverse p=1

U4 S METER DISPLAY—Selects single-segment pointer or bar graph meter on the NRD-535's display.

U40 <CR> Single-segment
 U41 <CR> Bar graph (default)

U5 MEMORY CHANNEL CLEAR—Erases contents of specified memory channel.

U5ccc <CR> ccc=channel No. (000 to 199)
 to clear ALL memory channels, see command Z.

U6 FREQUENCY DISPLAY—Sets display of local carrier frequency or 1.5 kHz offset during SSB reception.

U60 <CR> Display shift
 U61 <CR> Display local frequency (default)

U7 10 Hz DIGIT DISPLAY—Toggles the 10 Hz digit on and off in the receiver's display panel. This does not affect the ability of the radio to tune in 10 Hz (or 1 Hz) increments, but simply adds or removes that digit from the frequency readout.

U70 <CR> OFF
 U71 <CR> ON (default)

U8 CLOCK COLON BLINKING—Allows for blinking or non-

blinking colon when clock is displayed.

U80 <CR> Blink off
 U81 <CR> Blink on (default)

U9 BEEP—When on, the receiver will keep every time a button is pressed, i.e. during direct frequency entry via keypad.

U90 <CR> Beep off
 U91 <CR> Beep on (default)

V TUNING RATE—This command allows setting of tuning rate.

V0 <CR> 1 Hz rate
 V1 <CR> 10 Hz rate
 V2 <CR> 100 Hz rate

W BANDWIDTH CONTROL (BWC)—Sets desired width of BWC unit, from widest setting of ~~24~~^{5.5} kHz to narrowest setting of 500 Hz, in 10 Hz steps.

Wnnnnn <CR> nnnn=bandwidth in Hz
 (5500 to 2000)
 (2400 to 0500)

X RTTY OUTPUT—Send output of optional CMH-530 RTTY Demodulator to PC for display on monitor.

X0 <CR> RTTY output off
 X1 <CR> RTTY output on

Y UP/DOWN FREQUENCY TUNING—Tunes the receiver up or down without muting the received signal, until the STOP command is received.

Y+ <CR> Tune up
 Y- <CR> Tune down
 Y0 <CR> Stop tuning

Z RESET—Clears all memory channels and/or resets all user definitions to factory default settings.

Z1 <CR> Clear all memory channels
 Z2 <CR> Reset user definitions
 Z3 <CR> Total reset (both Z1 & Z2 commands)

5.6 USER DEFINITIONS

To provide the user with the greatest degree of operating flexibility, sixteen of the NRD-535's default CPU parameters can be changed according to the user's preference. The operations used to change these parameters are called User Definitions, and are described in detail in section 5.6.1.

To set or check the status of a User Definition, press the following keys:

MEMO **FUNCTION** **ENT/kHz**

The main display will indicate the User Definition number, from 1–16, to the left (in place of the memory channel number), and the present parameter setting to the right (in place of the frequency readout).

The User Definition number will initially blink on and off.

The MAIN TUNING DIAL can be used to select the User Definition you wish to change, or the number can be entered directly with the NUMERICAL KEYPAD. After selecting the desired User Definition number, press the ENT/kHz button; the parameter number will now blink on and off. The parameter can be changed by turning the MAIN TUNING DIAL. In addition, certain parameters can be set by directly entering the number with the NUMERICAL KEYPAD; only User Definitions No. 3, 4, 12 and 13 do not allow parameters to be changed with the keypad. After setting the desired parameter, press the ENT/kHz button again to store the setting.

To leave the User Definition mode, simply press either the FUNCTION or CLR button. Also, if the MAIN TUNING DIAL or any of the keys of the NUMERICAL KEYPAD are not pressed for 10 seconds, the receiver automatically exits the User Definition mode and returns its previous operating condition.

5.6.1 USER DEFINITION ITEMS AND PARAMETERS

The following details all User Definitions, including the changeable parameters for each. Numbers shown inside small boxes (for example,) indicate parameter settings:

USER DEF. #	DESCRIPTION/PARAMETERS
-------------	------------------------

1 OPERATION OF TIMER RELAY TERMINAL—The TIMER OUT relay terminal on the rear panel operates as a timer-controlled switch. This User Definition determines when the relay is opened and closed.

- Parameters: = Normally OFF (default)
 = Normally ON
 = ON/OFF according to SQUELCH

2 BYPASS FRONT-END TUNING FILTERS—The Variable Bandpass Tuning filter in the receiver's front end can be bypassed if desired. This may cancel a small amount of attenuation of incoming signals, but may also increase the likelihood of interference from strong out-of-band signals. We recommend that this feature NOT be used except temporarily in special circumstances.

- Parameters: = Bypass filter
 = Enable filter (default)

3 BFO OFFSET FREQUENCY—The BFO offset for CW operation can be set with the MAIN TUNING DIAL, from -5000 Hz to +5000 Hz.

Parameters: -5000 to +5000 (default +800)

4 RTTY BAUD RATE—If the optional CMH-530 RTTY Demodulator is installed, this User Definition is used to set the baud rate, from 37 to 75 baud.

Parameters: 37 to 75 (default 45)

5 RTTY SHIFT WIDTH—If the optional CMH-530 RTTY Demodulator is installed, this User Definition is used to set the shift width.

- Parameters: = 170 Hz (default)
 = 425 Hz
 = 850 Hz

6 RTTY POLARITY—If the optional CMH-530 RTTY Demodulator is installed, this User Definition is used to set the polarity according to the received signal.

- Parameters: = Reverse
 = Normal (default)

7 S-METER DISPLAY—Changes the display style of the digital S-meter from bar graph to single-segment pointer.

- Parameters: = Single-segment meter
 = Bar graph meter (default)

8 SSB FREQUENCY DISPLAY—Determines if displayed frequency is shifted during mode changes.

- Parameters: = Frequency shifted during mode changes
 = No shift in frequency during mode changes (default)

9 10 Hz DIGIT DISPLAY—The 10 Hz digit may be dropped from the display with this User Definition.

- Parameters: = No 10 Hz digit shown
 = 10 Hz digit shown (default)

10 BLINKING COLON ON CLOCK/TIMER DISPLAY—When the CLOCK or TIMER is on, the colon can be set to blink on and off in one-second intervals, or remain lit continuously.

Parameters: 0 =Continuously lit colon
 1 =Blinking colon (default)

11 BEEP-The beep sound, heard when buttons are pressed, can be toggled on and off.

Parameters: 0 =Beep OFF
 1 =Beep ON (default)

12 SCAN RATE-Sets the amount of time that the receiver remains on one channel during scan operations, from 0.5 to 5 second per channel.

Parameters: 0.5 to 5 (default 1)

13 SWEEP RATE-Sets the amount of time that the receiver remains on one frequency during sweep operations, from 0.05 to 0.5 second per frequency step.

Parameters: 0.05 to 0.5 (default 0.05)

14 RTTY OUTPUT-If the optional CMH-530 RTTY Demodulator is installed, the output data from the demodulator is sent through the RS-232C interface. This User Definition allows the user to turn the data flow ON and OFF.

Parameters: 0 =RTTY Data flow OFF
 1 =RTTY Data flow ON (default)

15 AUTO-STOP-If AUTO-STOP is set ON, the NRD-535 automatically pauses during scan and sweep operations whenever the received signal exceeds the SQUELCH threshold.

Parameters: 0 =AUTO-STOP OFF (default)
 1 =AUTO-STOP ON

16 TUNING RATE OF MAIN TUNING DIAL-The number of steps per revolution of the MAIN TUNING DIAL is selectable. It is normally set for 1000 steps per revolution, but can be changed to 250 steps per revolution if a slower rate is desired.

Parameters: 0 =250
 1 =1000 (default)

5.7 RTTY DEMODULATOR

With the optional CMH-530 RTTY Demodulator installed you may receive radioteletype signals, decode them and output the received

data through the RS-232C interface port for displaying and processing the data with a personal computer. Installation of the RTTY Demodulator is described in section 8.

Any simple telecommunications terminal program may be used to receive and capture RTTY text from the NRD-535, or a specialized terminal program can be designed specifically for this purpose.

The RTTY data are output from the receiver through the RS-232C interface whenever the RTTY mode is selected. The flow of data can be turned on and off with User Definition No. 14 or the "X" interface command.

5.7.1 SETTING RTTY PARAMETERS

The RTTY signal parameters (SPEED, SHIFT and POLARITY) are set with User Definitions No. 4, 5, and 6, respectively. They may also be set via the RS-232C Interface by the "U3" command (see section 5.5.3).

Determining the baud rate, shift and polarity of an unknown station may take some time and effort (and often a bit of luck). Trial and error sometimes is the only way. However, if you know the type of transmission, here are some of the more common settings:

TYPE OF SIGNAL	BAUD RATE	SHIFT
Amateur radio	45	170 Hz
Press services	50	425 Hz
Meteorological	75	850 Hz

As for polarity, either NORMAL or REVERSE may be used at any time. Both settings may be tried until error free reception occurs. The above chart shows typical, not exclusive, settings. Parameters other than those listed may be used by the transmitting station.

When storing memory channel information that includes the RTTY mode, the SPEED, SHIFT and POLARITY settings are also stored in the memory channel along with FREQUENCY, AGC, BANDWIDTH, etc.

5.7.2 TUNING RTTY STATIONS

After finding a RTTY signal, the NRD-535 should be fine-tuned until the MARK and SPACE indicators of the CKJ-61 Indicator Unit (furnished with the CMH-530) alternately flash. Provided the parameters are set properly as described in section 5.7.1 above, the demodulated data will be sent to the PC or terminal unit via the RS-232C port. Fine tuning of the SPACE filter can be done with the TONE control; normally, it is set to the 12 o'clock position.

For more accurate tuning indication, an oscilloscope's X and Y inputs may be connected to the MARK and SPACE jacks instead of the CKJ-61 Indicator Unit. Proper tuning is achieved when the cross-hair traces of the scope are perpendicular.

SECTION 6: ADJUSTMENT AND MAINTENANCE

6.1 ADJUSTMENT

Your NRD-535 has been carefully aligned and inspected at the factory before shipment, and therefore should not require any adjustments other than the ones described below.

In the event that your receiver does require repair or major adjustment, such work should be performed by an authorized JRC service center.

6.1.1 BEEP LEVEL

To adjust the volume of the beep tone, carefully turn the receiver upside down and locate the access hole for the beep level control. A small screwdriver can be used to adjust the control until the desired volume is obtained (see Fig. 6-1).

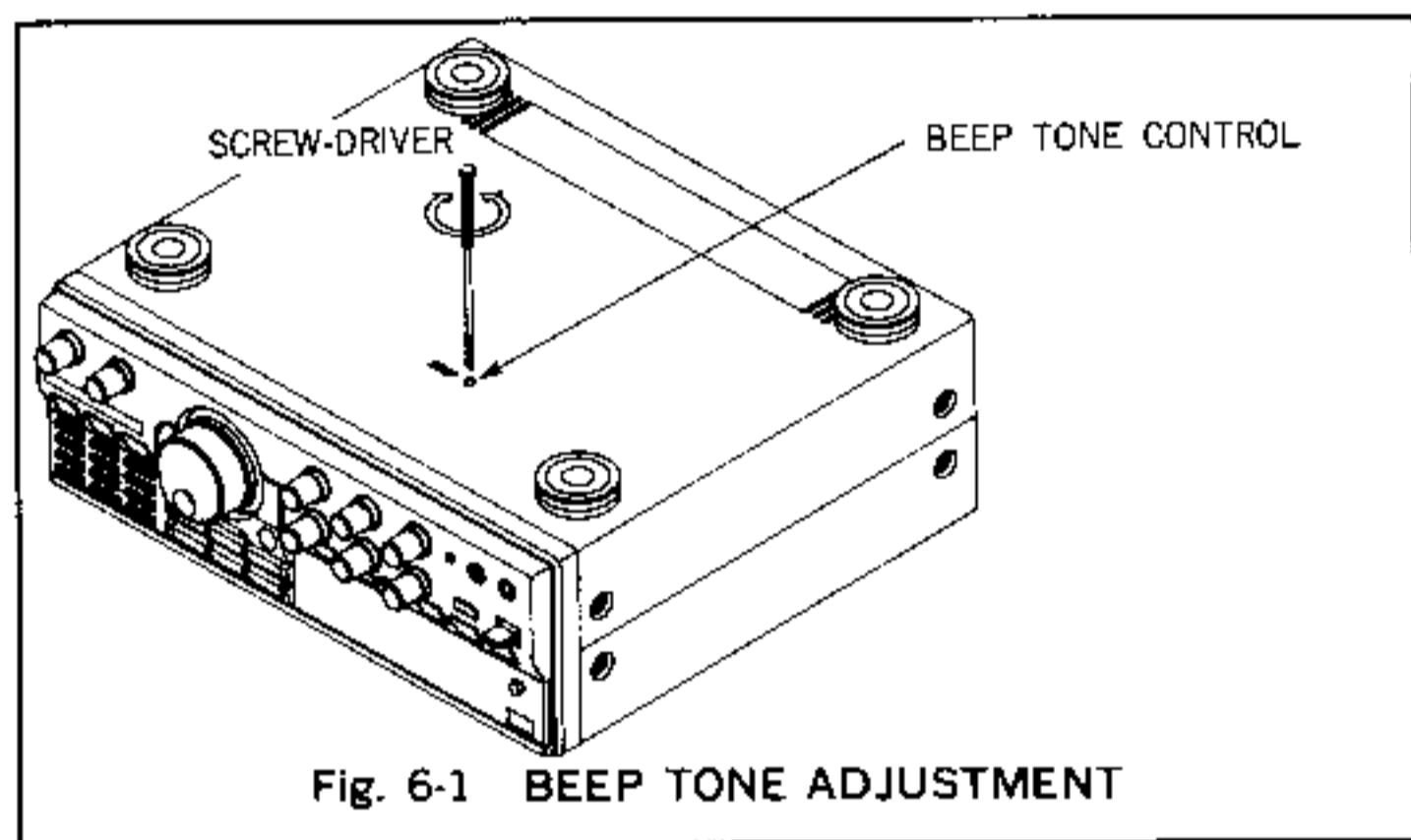
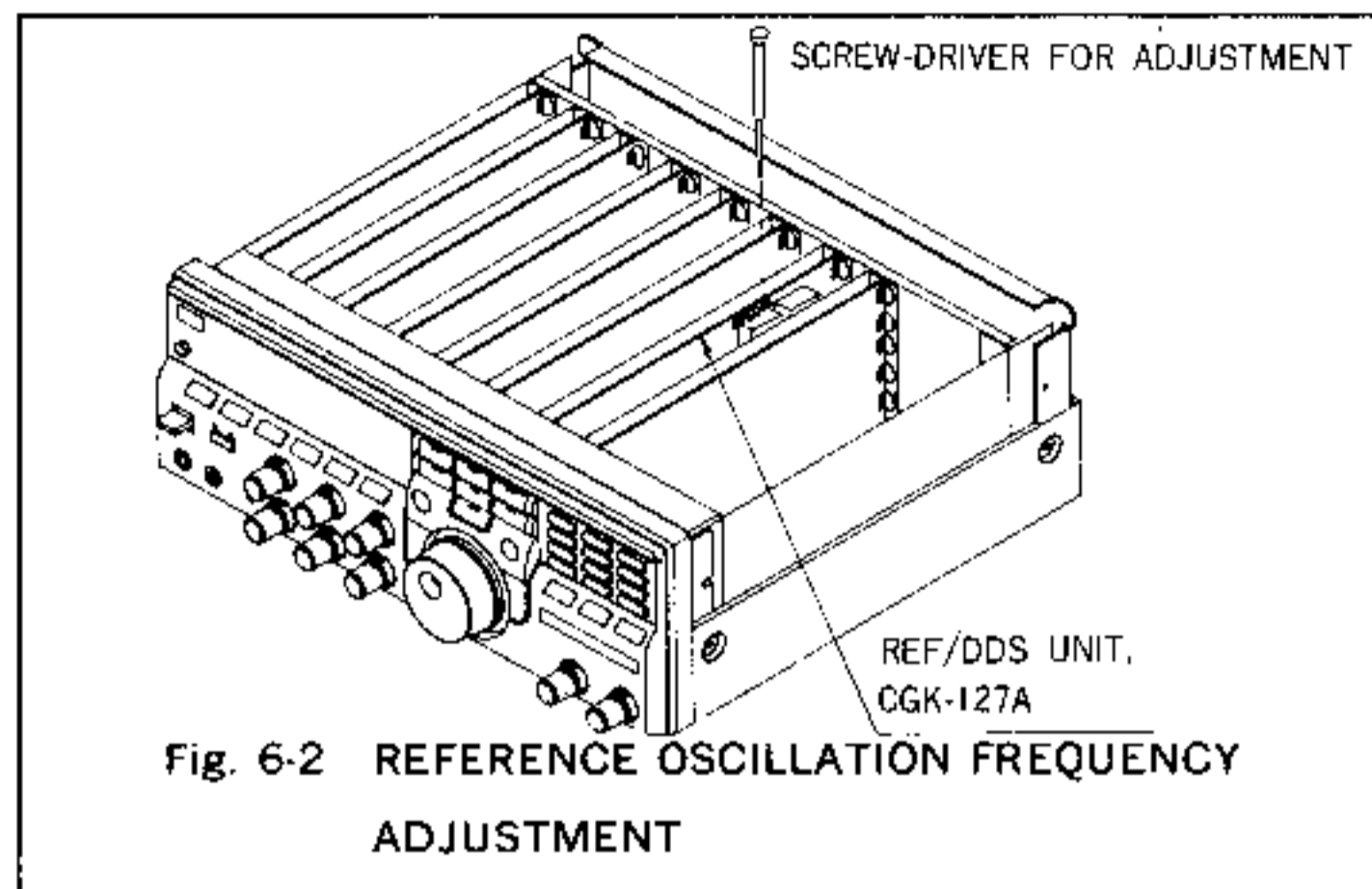

Fig. 6-1 BEEP TONE ADJUSTMENT

6.1.2 REFERENCE OSCILLATOR FREQUENCY ADJUSTMENT

To adjust the frequency of the reference oscillator:

1. With the POWER switch set to OFF, remove the top cover of the NRD-535. Do not disconnect the speaker cable from the IF AMP board unless an external speaker is being used.
2. Turn the POWER switch ON and tune to a standard time station (WWV, JJY, etc.). It is recommended that the 10 Hz tuning rate be used to ensure exact tuning of the station.
3. Select the CW mode and set the BFO offset to 0 Hz by using User Definition No. 3 (see section 5.6). Set bandwidth to WIDE.
4. Adjust trimmer capacitor CV1, located at the top of the shield case of the REF/DDS board (CGK-127A), until no beat note is heard (see Fig. 6-2).
5. Reset the BFO offset to desired setting. Turn the POWER switch OFF and replace the top cover.



6.2 MAINTENANCE

6.2.1 ELECTRONIC COMPONENTS

The ICs, transistors and diodes of the NRD-535 are extremely sensitive and will be destroyed if short-circuited even for an extremely short period of time, or exposed to static discharges. Therefore it is important to take special care that the top and bottom covers are in place at all times during operation. If internal adjustments must be made while the power is on, extreme caution is advised. Avoid excessive handling of printed circuit boards, and use proper anti-static protection during handling.

6.2.2 FUSE

If the power fuse is blown, try to determine the cause. If it is certain that the radio is not at fault, replace the fuse. The AC fuse is located on the rear panel. The DC fuse is located in the fuse holder of the DC power cable.

6.2.3 LITHIUM CELL

The NRD-535's memory channel information is backed up by a lithium cell located on the CPU board (CDC-493AD). It should function properly for more than 5 years before requiring replacement.

If the memory channel information is repeatedly lost, or no information is stored, the lithium cell may need to be replaced. Follow these steps to remove the old cell and install a new replacement (see Fig. 6-3):

1. Disconnect all power cables from the NRD-535.
2. Remove the top cover.
3. Remove the CPU board (CDC-493AD; see section 8 for removal instructions).
4. Desolder the existing cell and remove from the CPU board. Replace with the new cell (Matsushita Denki Sangyo type

CR2032-1HS).

5. Replace the CPU board and top cover.

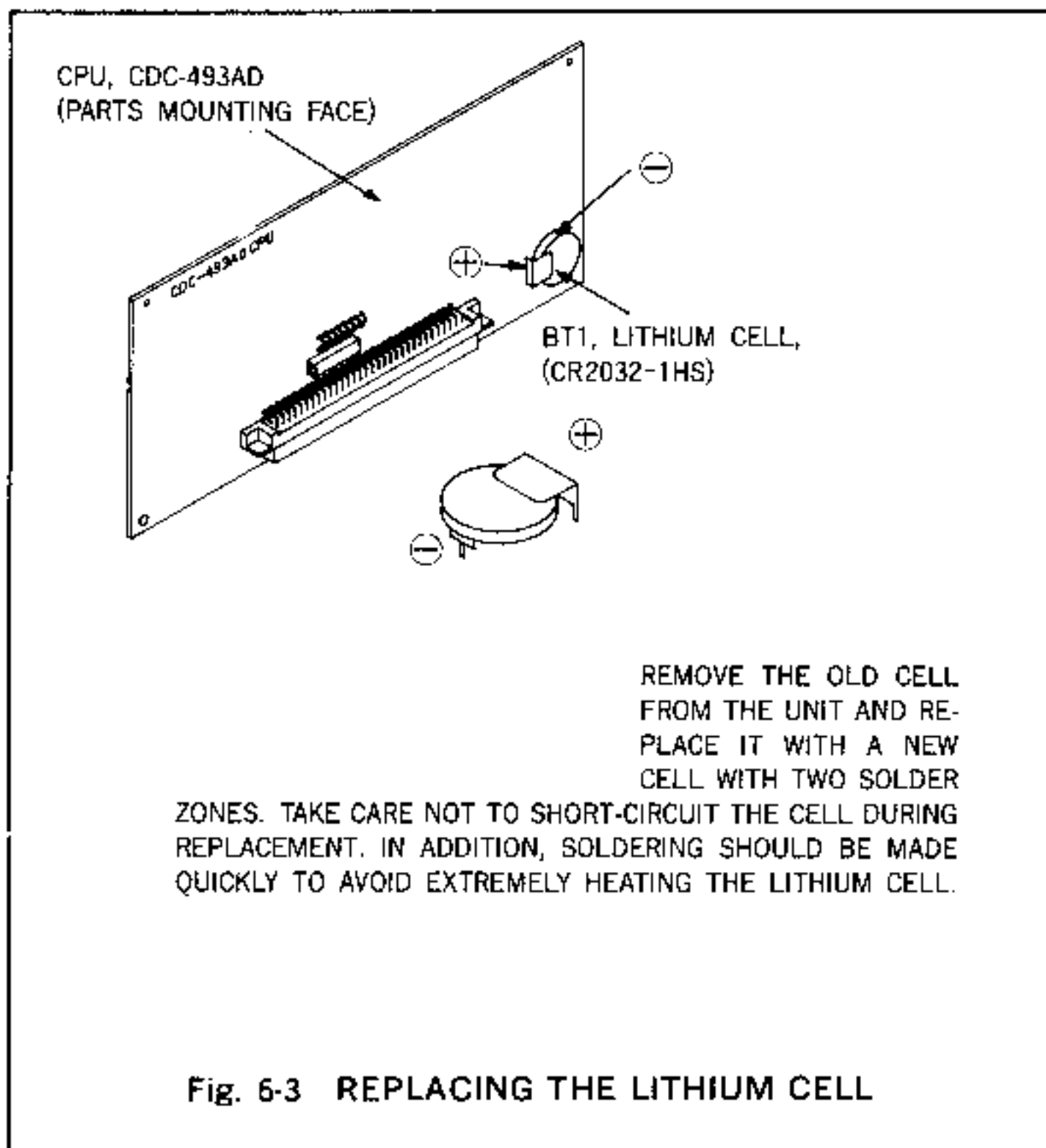

SECTION 7: TROUBLESHOOTING

7.1 SIMPLE PROBLEMS

The NRD-535 provides many advanced features and functions for maximum flexibility and operator convenience. However, the features don't always perform in ways you expect. Therefore, if you experience what you believe to be a problem, please check all receiver settings and User Definitions to be certain that the radio is not merely set improperly for the current receiving application.

The following table lists symptoms and remedies for several common problems.

No display appears when power is switched on.	<ol style="list-style-type: none"> 1. Power connector is not perfectly connected. 2. Fuse is blown. 	<ol style="list-style-type: none"> 1. Check power connections. 2. Replace fuse.
No sound is heard, but display works normally.	<ol style="list-style-type: none"> 1. Headphones connected to PHONES jack. 2. Squelch is closed. 3. RF GAIN control is set to full counterclockwise position. 	<ol style="list-style-type: none"> 1. Disconnect headphones. 2. Set SQUELCH control OFF. 3. Set RF GAIN control to full clockwise position.
Display appears too dark.	Dimmer set for minimum brightness.	Set dimmer to brighter position.
S-Meter gives a reading greater than zero when no signal is being received.	RF GAIN control set for reduced gain.	Turn RF GAIN control clockwise.
Distorted sound and/or poor audio quality	<ol style="list-style-type: none"> 1. AGC is set OFF. 2. Receiver is off tuned off frequency. 3. Wrong mode is selected. 4. NOTCH filter is ON. 5. PBS control is not set to 12 o'clock position. 6. Noise blanker (NB) is ON. 	<ol style="list-style-type: none"> 1. Set AGC to FAST or SLOW. 2. Adjust MAIN TUNING DIAL. 3. Select proper mode for incoming signal. 4. Set NOTCH control to OFF position. 5. Set PBS to 12 o'clock position. 6. Set noise blanker to OFF.
Low sensitivity.	<ol style="list-style-type: none"> 1. ATT is set ON. 2. Antenna is not connected. 3. Proper antenna input is not selected. 	<ol style="list-style-type: none"> 1. Set ATT to OFF. 2. Connect antenna to receiver. 3. Select proper antenna with selector switch on rear panel.

If after checking the above symptoms your receiver still does not work properly, contact your dealer or nearest JRC office or service center.

7.2 MORE SERIOUS PROBLEMS

7.2.1 ERRONEOUS DISPLAY AND ABNORMAL RECEIVING CONDITIONS

Due to the rigors of transportation, the NRD-535's internal circuit boards may possibly be loosened from their motherboard connections, causing poor contact. Under such circumstances it is possible that erroneous display readings and other abnormalities may result. If you experience such problems, remove the top cover of the receiver (with POWER switch set to OFF position) and press each of the modular circuit boards down to be sure that they are properly seated to their motherboard connectors. Then replace the top cover.

7.2.2 RFI EMISSION

The NRD-535 has been adequately shielded to eliminate RF radiation from the set. However, inadequate grounding and/or antenna installation can sometimes cause the set to cause noise interference to other electronic devices.

If you experience such trouble, try the following:

1. Replace the grounding wire of the NRD-535 and the other device with a wire that has a thicker conductor. Be sure that all connections are secure, and all runs of wire are as short as possible.
2. Place the other device (or its antenna) as far from the NRD-535

and its antenna as possible.

3. If the other device is a television or FM receiver, try changing the orientation of the set's antenna, or replace it with a higher-performance antenna.
4. Power the NRD-535 and the other device from separate power sources.
5. Insert a noise filter or isolation transformer in the power source line.

7.2.3 NOISE INTERFERENCE FROM OTHER SOURCES

There are numerous artificial and natural noise sources that can plague radio monitors. Natural noise can be caused by nearby thunder, rain and snow storms. Artificial noise from motorcycle and auto ignitions, power lines, sewing machines, personal computers, microwave ovens, fluorescent lights, hair dryers, etc., can also enter the receiver through the antenna and/or power cable. Also, nearby radio stations can cause noise, especially if the transmitter or antenna is of poor quality.

Unfortunately, there is no easy way to eliminate all types of noise. Usually, such countermeasures must be taken at the noise source itself, which may not always be possible or practical.

Improvements to your ground system often result in reduced noise. Also, your choice of antenna design may have a great effect on the amount of noise you receive. For example, a horizontal loop antenna is inherently better at reducing electrical noise than, say, an active-type receiving antenna.

SECTION 8: OPTIONAL UNITS

8.1 INTRODUCTION

To operate the NRD-535 more effectively and more comfortably, several helpful units are available at your option, as described below.

■BWC UNIT, CFL-243

If the BWC unit is incorporated, you can continuously change the pass bandwidth from 2.4 kHz to approximately 500 Hz, without changing the center frequency of the Receiver IF filter.

1. PACKAGE CONTENTS

BWC unit, CFL-243	1
Printed circuit board puller	2
Instruction manual	1

CAUTION

The instruction manual appended to the BWC unit, CFL-243, is prepared for the JST-135. Do not use this manual.



BWC UNIT, CFL-243

2. INSTALLATION

Before you take up the installation work, always set the POWER/TIMER ON-OFF switch of the NRD-535 and disconnect the power cable.

In addition, do not touch the units in the NRD-535, unless necessary.

- 1) Remove the upper and lower covers according to Section 8.2 "REMOVING COVERS".
- 2) Turn the Receiver set with the bottom face upwards enough to well see the motherboard, CFQ-3597.
- 3) According to Fig. 8-1, cut off the printed pattern of JP1 on the motherboard.

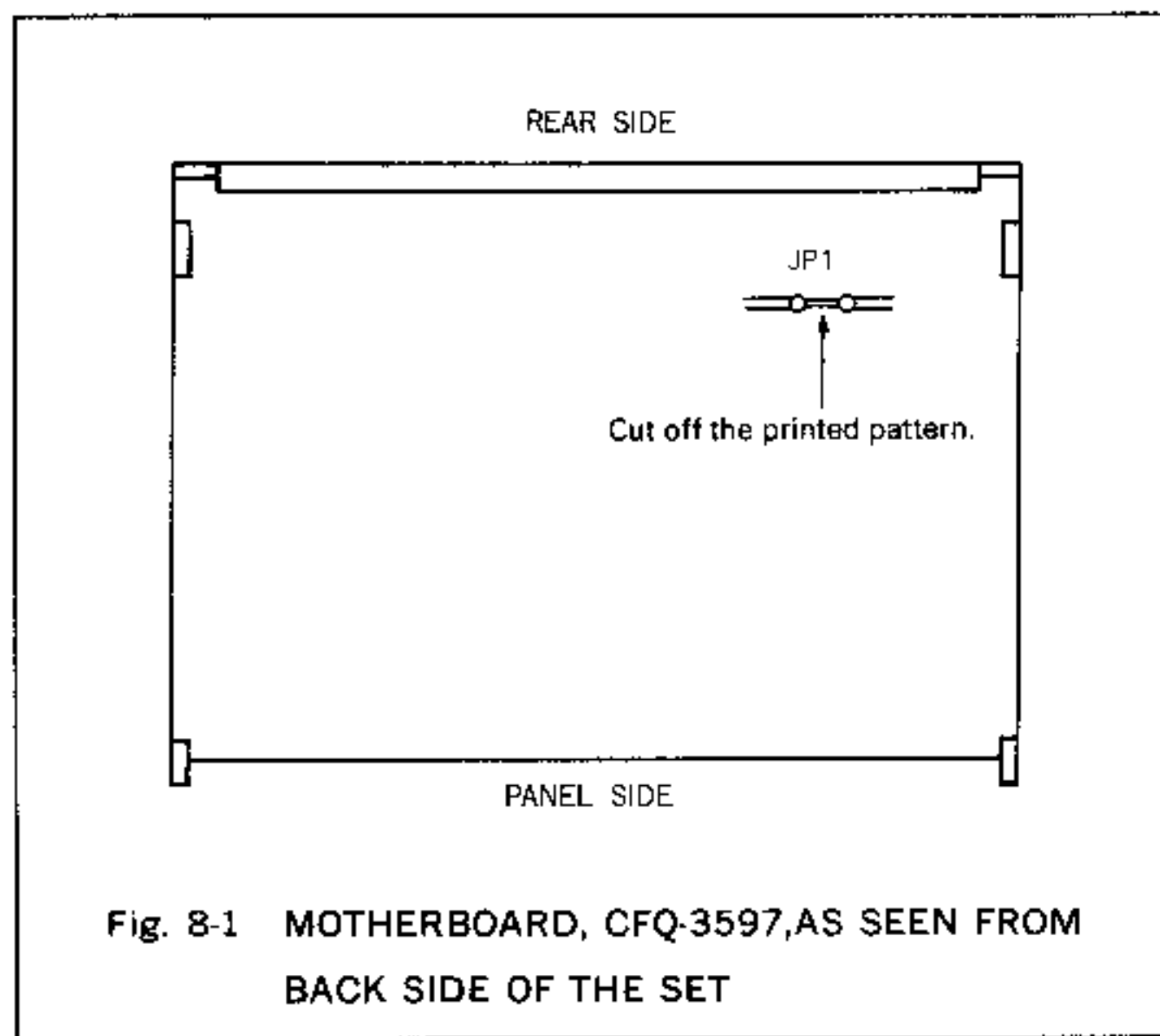

Fig. 8-1 MOTHERBOARD, CFQ-3597, AS SEEN FROM BACK SIDE OF THE SET

- 4) After cutting the JP1 on the motherboard, mount the lower cover on the Receiver set.
- 5) Then, put the set, so as to allow its upper side to be seen. Insert the BWC unit, CFL-243, in place, according to Fig. 8-7.

If the insertion is imperfect, the Receiver may not work because of the poor contact.

To avoid this, fully insert along the rails, until tight.

- 6) Mount the upper cover.

Now, the installation of the BWC unit, CFL-243, is completed.

3. OPERATION

Once the BWC unit, CFL-243, is incorporated, the CPU in the NRD-535 automatically senses to make the BWC unit go into the operating state.

For the operating method, refer to Section 4. ⑨.

■ECSS UNIT, CMF-78

The ECSS unit incorporated in the NRD-535 provides selectable sidebands. Therefore, you can select one of the sidebands, which is not subjected to the interference during the reception of the AM wave, without using the narrow-band filter.

Thus, it serves for eliminating the radio interference.

1. PACKAGE CONTENTS

ECSS unit, CMF-78	1
Printed circuit board puller	2

CAUTION

The instruction manual appended to the ECSS unit, CMF-78, is prepared for the JST-135.
Do not use this manual.



ECSS UNIT, CMF-78

2. INSTALLATION

Before you take up the installation work, always set the POWER/TIMER ON-OFF switch of the NRD-535 and disconnect the power cable.

In addition, do not touch the units in the NRD-535, unless necessary.

- 1) Remove the upper cover according to Section 8.2 "REMOVING COVERS".
- 2) Insert the ECSS unit, CMF-78, in place, according to Fig. 8-7.

If inserting not perfectly, the Receiver may not work, because of the poor contact.

To avoid this, fully insert along the rails, until tight.

- 3) Mount the upper cover.
Now, the installation of the ECSS unit, CMF-78, is completed.

3. OPERATION

Once the ECSS unit, CMF-78, is incorporated, the CPU automatically senses to make the ECSS unit go into the operating state.

For the operating method, refer to Section 4, ②).

1. PACKAGE CONTENTS

RTTY demodulator unit, CMH-530	1
Indicator, CKJ-61	1
Printed circuit board puller	2
Output connector for printer	1
Instruction manual	1

CAUTION

The instruction manual appended to the RTTY demodulator unit, CMH-530, is prepared for the NRD-525.
Do not use this manual.
In addition, neither printer can be operated with the NRD-535, nor output connector for the printer is furnished.



RTTY DEMODULATOR UNIT, CMH-530

2. RATING

Demodulated code: 5-unit code according to CCITT, No. 2.
Shift width: 170 Hz, 425 Hz, and 850 Hz
Baud rate: 37-75 baud
Polarity: Normal and reverse
Output port: RS-232C interface

3. INSTALLATION

Before you take up the installation work, always set the POWER/TIMER ON-OFF switch of the NRD-535 and disconnect the power cable.

In addition, do not touch the units in the NRD-535, unless necessary.

- 1) Remove the upper cover according to Section 8.2 "REMOVING COVERS".
- 2) Insert the RTTY demodulator unit, CMH-530, in place, according to Fig. 8-7.

NOTE: As for the RTTY demodulator unit only, its parts-mounted face is opposite to those of other units, when it is incorporated in the Receiver set.

If inserting the unit not perfectly, the Receiver may not work, because of the poor contact.

To avoid this, fully insert along the rails, until tight.

■RTTY DEMODULATOR UNIT, CMH-530

Once the RTTY demodulator unit is incorporated, it demodulates the RTTY signal, which may be then transferred to a computer by way of the RS-232C line.

Thus, you may see the text on the display screen of the computer.

This requires a personal computer in any case.

3) Mount the upper cover.

Now, the installation of the RTTY demodulator unit, CMH-530, is completed.

4. EXTERNAL CONNECTION

1) Connect the furnished indicator, CKJ-61 to the rear panel of the NRD-535.

Upon the connection, you will find the marks M and S on the top end of the cable of the indicator.

Insert the plug at the mark M into the terminal MARK on the rear panel of the NRD-535. And, insert the plug at the mark S into the terminal SPACE.

2) Connect the personal computer to the NRD-535.

For the connecting method, refer to Section 5.5.

5. OPERATION

Once the RTTY demodulator unit CMH-530 is incorporated, the CPU automatically senses to make the RTTY demodulator unit go into the operating state.

For the operating method, refer to Section 5.7.

■ HIGH STABILITY CRYSTAL OSCILLATOR UNIT, CGD-135

This oscillator unit holds at a constant temperature the crystal oscillator for providing a reference frequency of oscillation for the synthesizer in the NRD-535. It ensures a frequency stability within ± 0.5 ppm in the temperature range of -20°C to $+50^{\circ}\text{C}$, thus greatly improving the frequency stability.

1. PACKAGE CONTENTS

Thermostatic case, H-6ZKJD00020	1
Crystal oscillator, H-6XHJD00195 (20 MHz)	1
Capacitor, ECQ-V1H104JZ (50 V, 0.1 μF)	1
Printed circuit board puller	2
Instruction manual	1

CAUTION

The instruction manual appended to the High stability crystal oscillator unit, CGD-135, is prepared for the JST-135.

Do not use this manual.

In addition, the furnished capacitor, ECQ-V1H104JZ (50 V, 0.1 μF) is not needed for the NRD-535.

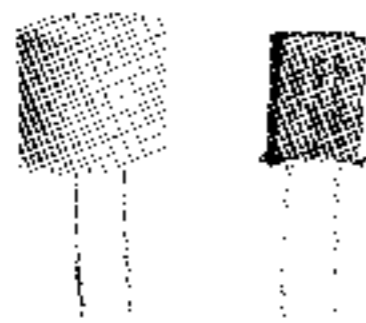

HIGH STABILITY CRYSTAL OSCILLATOR UNIT,
CGD-135

2. INSTALLATION

Before you take up the installation work, always set the POWER/TIMER ON-OFF switch of the NRD-535 and disconnect the power cable.

In addition, do not touch the units in the NRD-535, unless necessary.

1) Remove the upper cover according to Section 8.2 "REMOVING COVERS".

2) Pull off the REF/DDS unit, CGK-127A from the Receiver set, with referring to Section 8.3.

3) Remove both central shield cases from the solder side and parts-mounted side of the REF/DDS unit, CGK-127A.

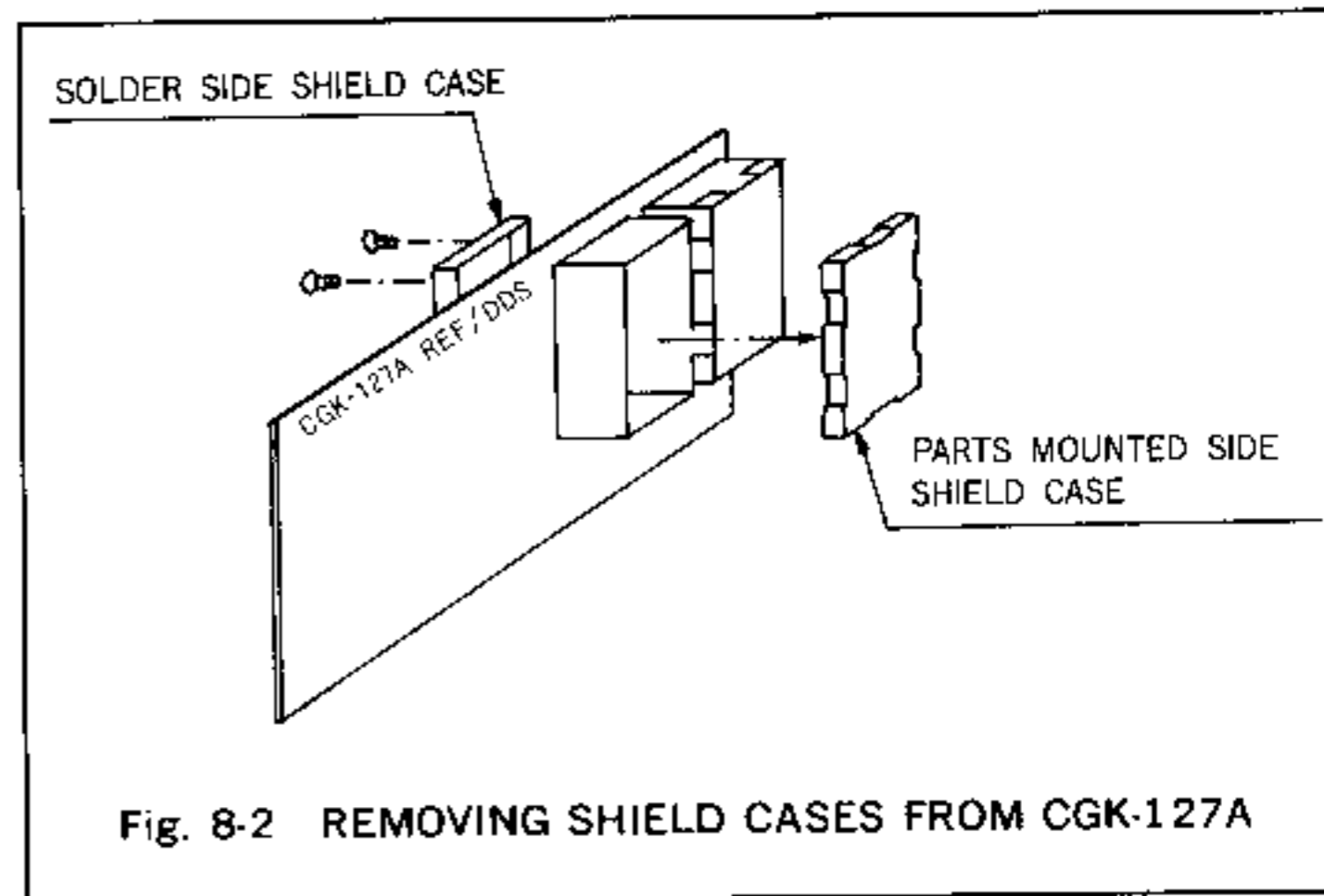

Fig. 8-2 REMOVING SHIELD CASES FROM CGK-127A

4) Mount the crystal oscillator (6ZXJD00195) furnished to the CGD-135, at the place X2 in the remaining shield case.

5) Cover the thermostatic case (6ZKJD00020) furnished to the CGD-135, over the mounted crystal oscillator X2.

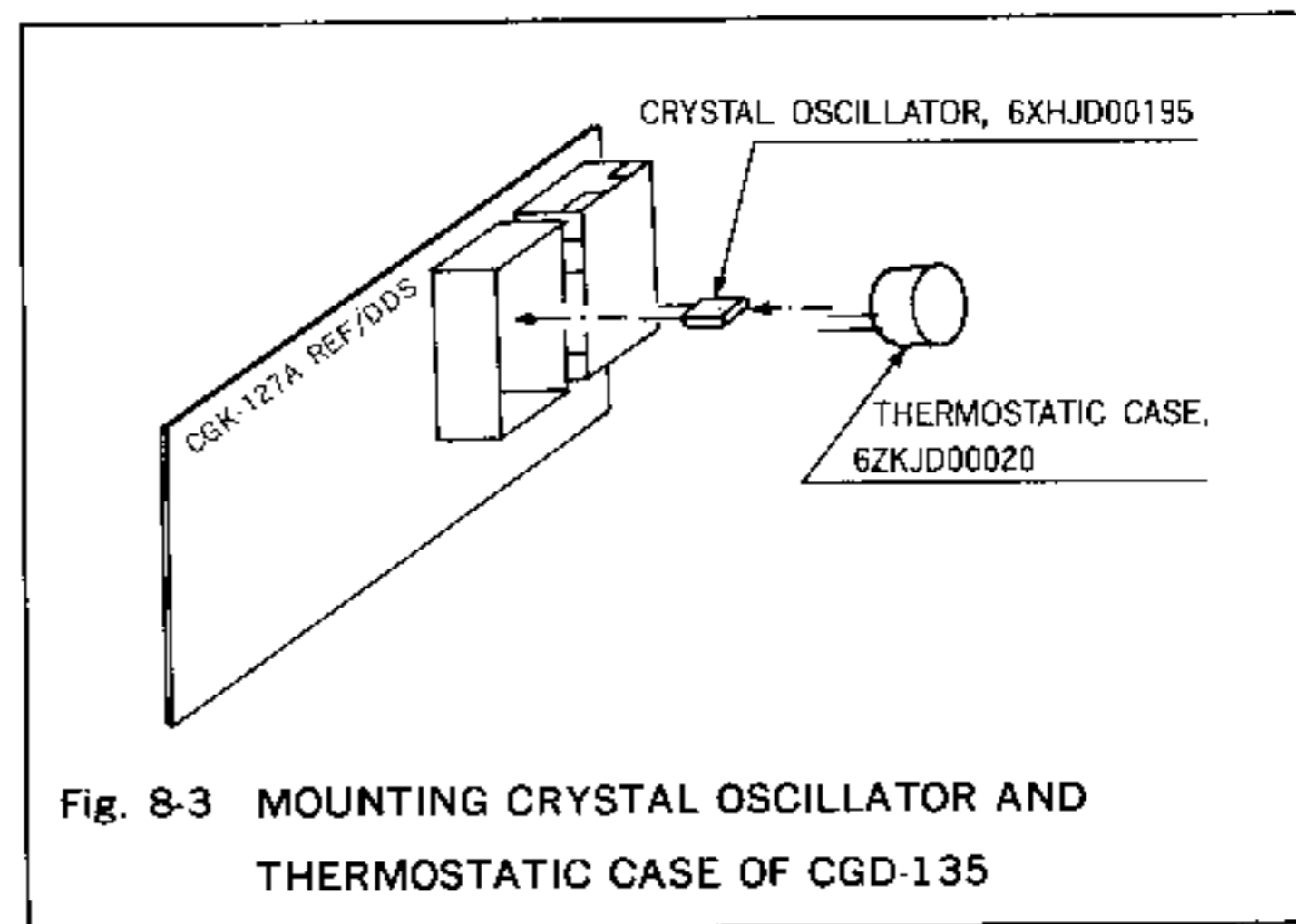

Fig. 8-3 MOUNTING CRYSTAL OSCILLATOR AND THERMOSTATIC CASE OF CGD-135

6) Solder the lead wires of the crystal oscillator and thermostatic case.

7) Return the shield cases to the original place, as they were. Then, insert the printed circuit board in place, until tight.

8) Set the crystal oscillator selecting parts S1 to the position **SPR**, which is located on the upper part of the shield case.

3. ADJUSTMENT OF REFERENCE FREQUENCY

- 1) Set the POWER/TIMER ON-OFF switch of the NRD-535 to ON. Allow for approximately 5 minutes, until the thermostatic case is warmed up.
- 2) Adjust the reference frequency of oscillation according to Section 6.1.2.
Slowly rotate the trimmer capacitor CV2 for desired frequency.
- 3) Mount the upper cover finally.

4. OPERATION

Approximately 2 minutes is required at room temperature for warming the thermostatic case up to a stationary temperature. Accordingly, upon the start of operation, allow for approximately 2 minutes after the POWER switch is turned on.

IF FILTERS

Five types of crystal filters are available for the SSB, CW and RTTY signals.

The NRD-535 is capable of incorporating two IF filters: one in the NARR place and the other in the AUX place.

1. TYPE

CFL-231	(300 Hz)
CFL-232	(500 Hz)
CFL-233	(1 kHz)
CFL-218A	(1.8 kHz)
CFL-251	(2.4 kHz)

Each IF filter is furnished with the following components as accessories.

Printed circuit board puller	2
Nut for mounting	2
Washer	2
Instruction manual	1

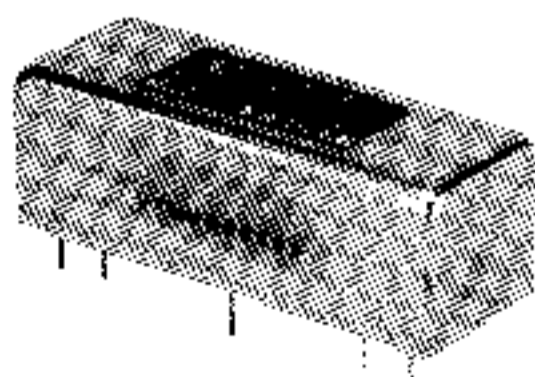

CRYSTAL FILTER

2. INSTALLATION

Before you take up the installation work, always set the POWER/TIMER ON-OFF switch of the NRD-535 and disconnect the power cable.

In addition, do not touch the units in the NRD-535, unless necessary.

- 1) Remove the upper cover according to Section 8.2 "REMOVING COVERS".
- 2) Pull off the IF FILTER unit, CFH-36A from the Receiver set, with referring to Section 8.3.
- 3) Mount the IF filter according to Fig. 8-4.

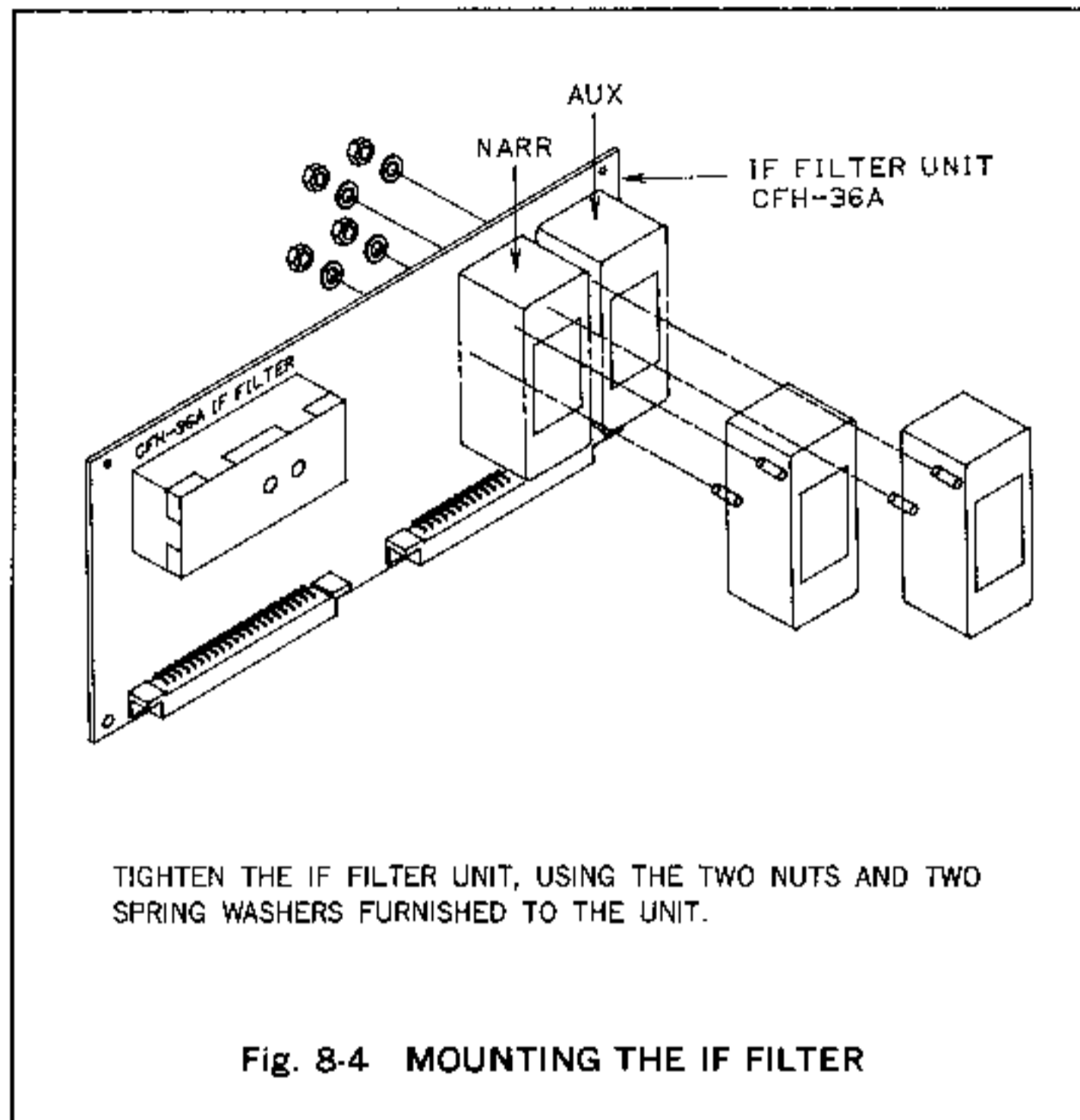

- 4) Change over the jumper wire according to Fig. 8-5.

After the above modification, you may set the bandwidth selector switch to the NARR position for selecting the filter in the NARR place of the CFH-36A and to the AUX position for selecting the filter in the AUX place of this unit.

If cutting the RJ0 of the CPU, CDC-493AD, the function of the bandwidth selector switch can be changed such that the filter in the AUX place is selected by setting to the NARR position and the filter in the NARR place is selected by setting to the AUX position.

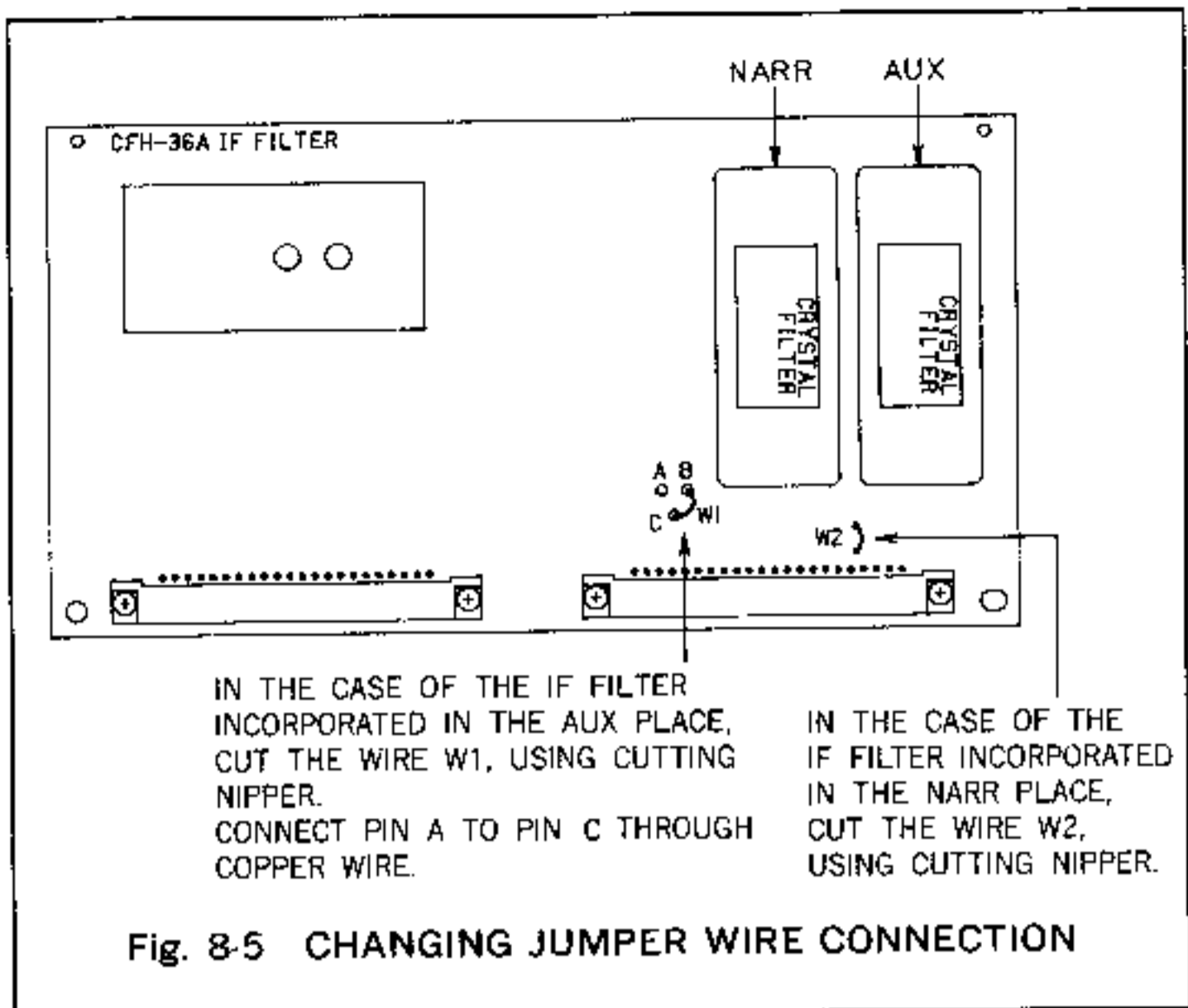
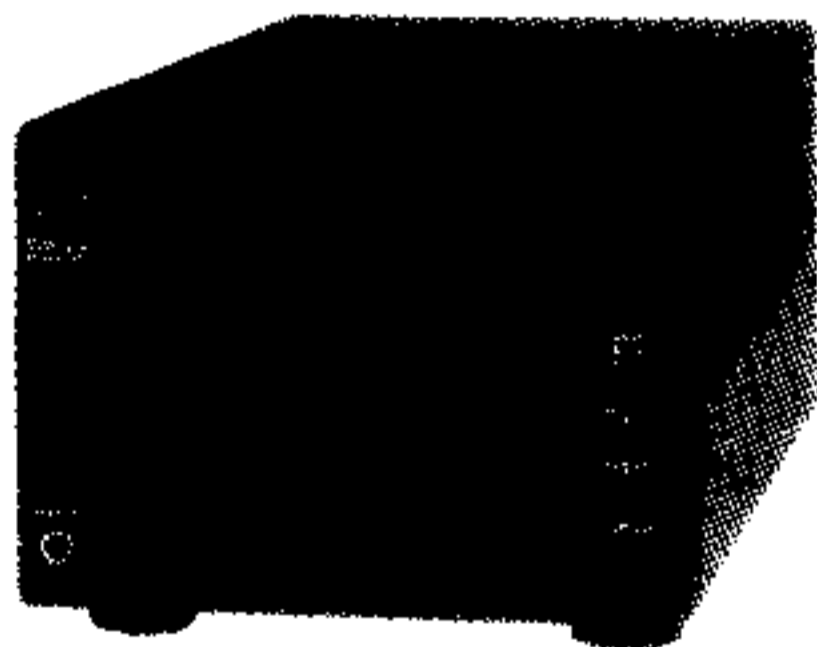

Fig. 8-5 CHANGING JUMPER WIRE CONNECTION

- 5) Return the IF filter unit, CFH-36A, to the original position and mount it in place.
Insert the unit along the guide rails, until tight.
- 6) Mount the upper cover.
Now, the filter change is completed.

■ EXTERNAL SPEAKER, NVA-319

The NVA-319 is a large-sized speaker of a good design matched with the NRD-535. It contains passive AF filters.



EXTERNAL SPEAKER, NVA-319

■ HEADPHONE, ST-3

The ST-3 is a headphone designed for the communication use.



HEADPHONE, ST-3

■ RS-232C CABLE, 6ZCJD00350

Exclusive cable for connecting the NRD-535 with a personal computer.

8.2 REMOVING COVERS

Remove the upper cover or lower cover according to Fig. 8-6.

Upon the uncovering, remove four setscrews.

On the upper cover, the speaker is mounted.

Slowly remove the cover, with taking care not to cut the cable of the speaker.

If necessary, remove the connector on the top end of the cable from the internal unit.

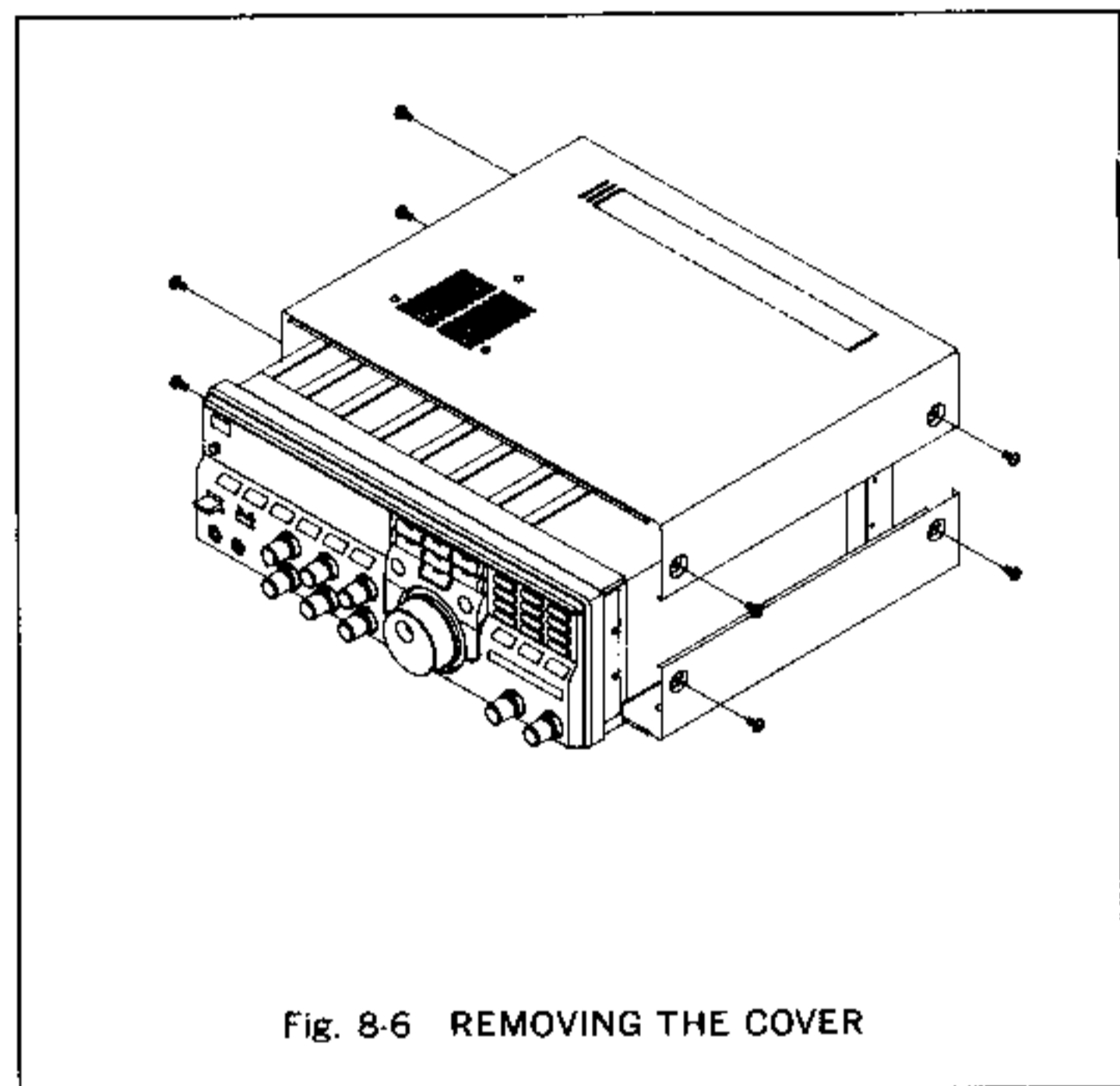
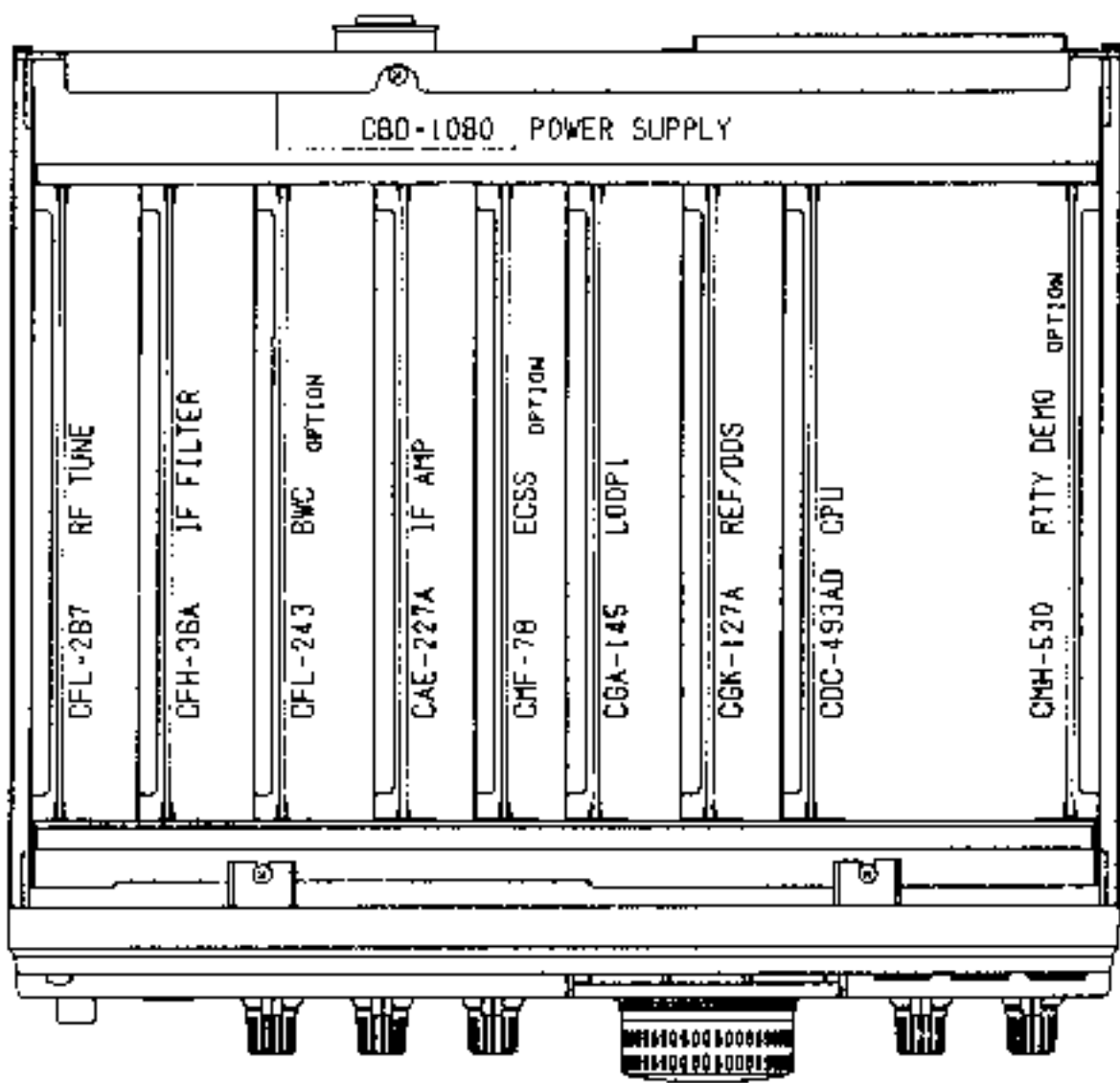

Fig. 8-6 REMOVING THE COVER

8.3 REMOVING INTERNAL UNITS

The layout of the internal units is shown in Fig. 8-7.

- 1) Each optional unit is furnished with the printed circuit board pullers.
Insert the furnished printed circuit board pullers into the holes located at the opposite corners of the printed circuit board from the parts-mounted face.
Refer to Fig. 8-8.
- 2) Push down the printed circuit board pullers to lever up the printed circuit board.
- 3) If the printed circuit board is released from the connector, slowly pull up the board.



CDE-705 DISPLAY

Fig. 8-7 LAYOUT OF UNITS OF NRD-535

PRINTED CIRCUIT
BOARD PULLER

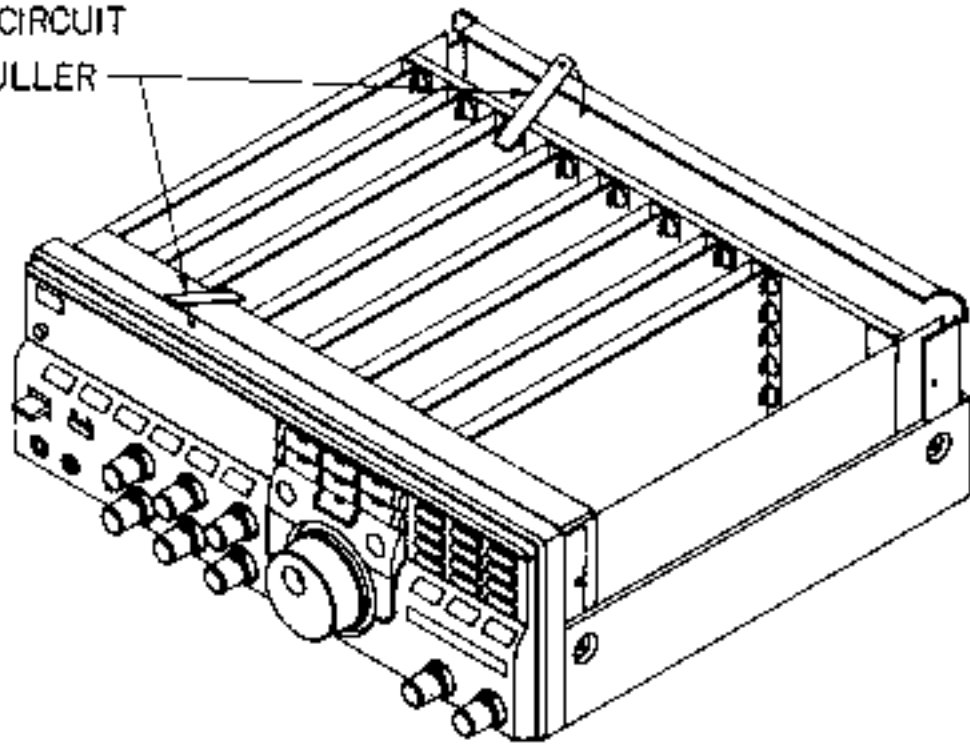
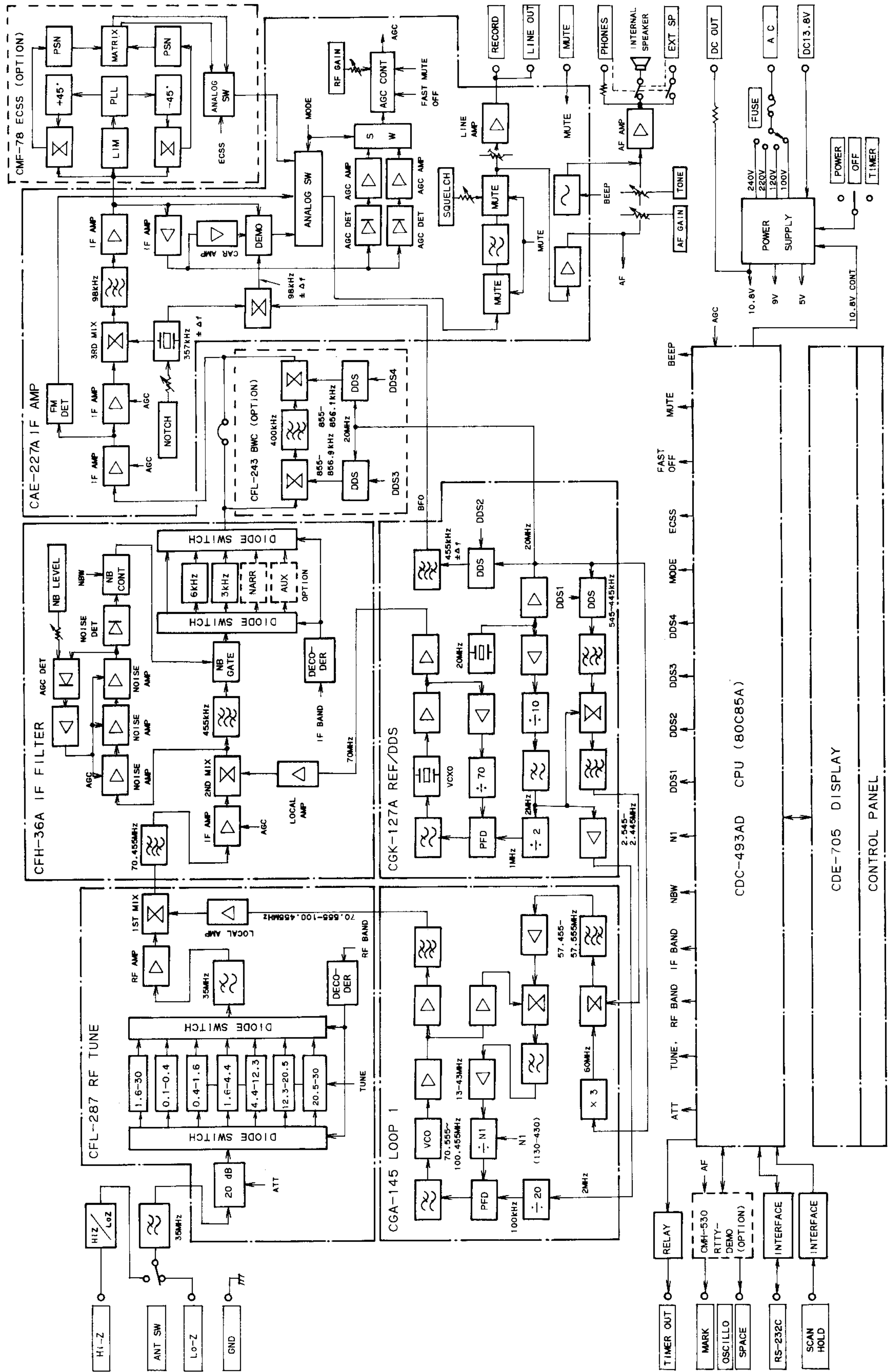

Fig. 8-8 REMOVING THE INTERNAL UNIT

SECTION 9: BLOCK DIAGRAM



SECTION 10: CIRCUIT DIAGRAMS

NRD-535 CHASSIS

CIRCUIT AND COMPONENTS SUBJECT TO CHANGE FOR AN IMPROVEMENT WITHOUT NOTICE.

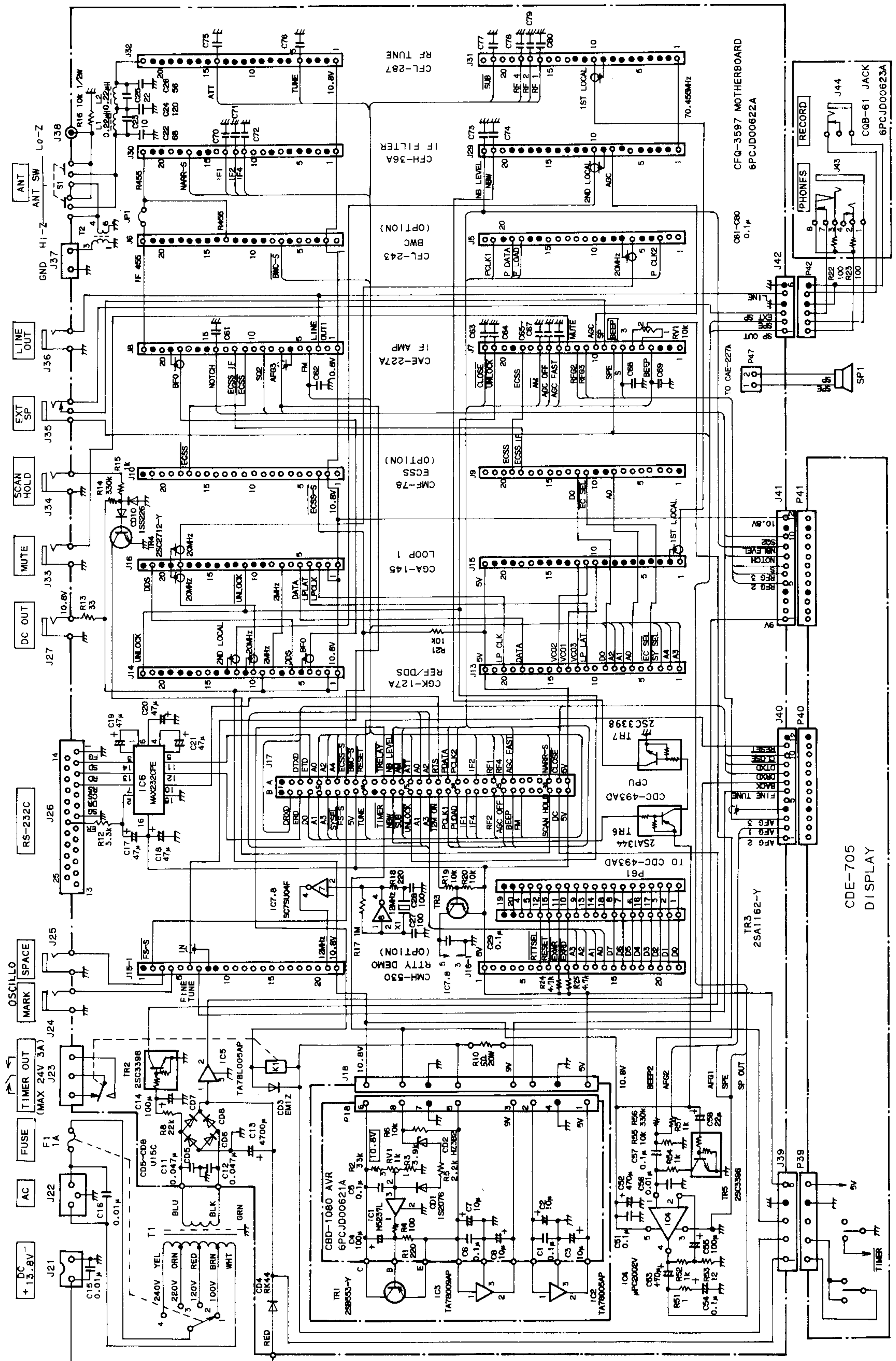

CFL-287 RF TUNE UNIT

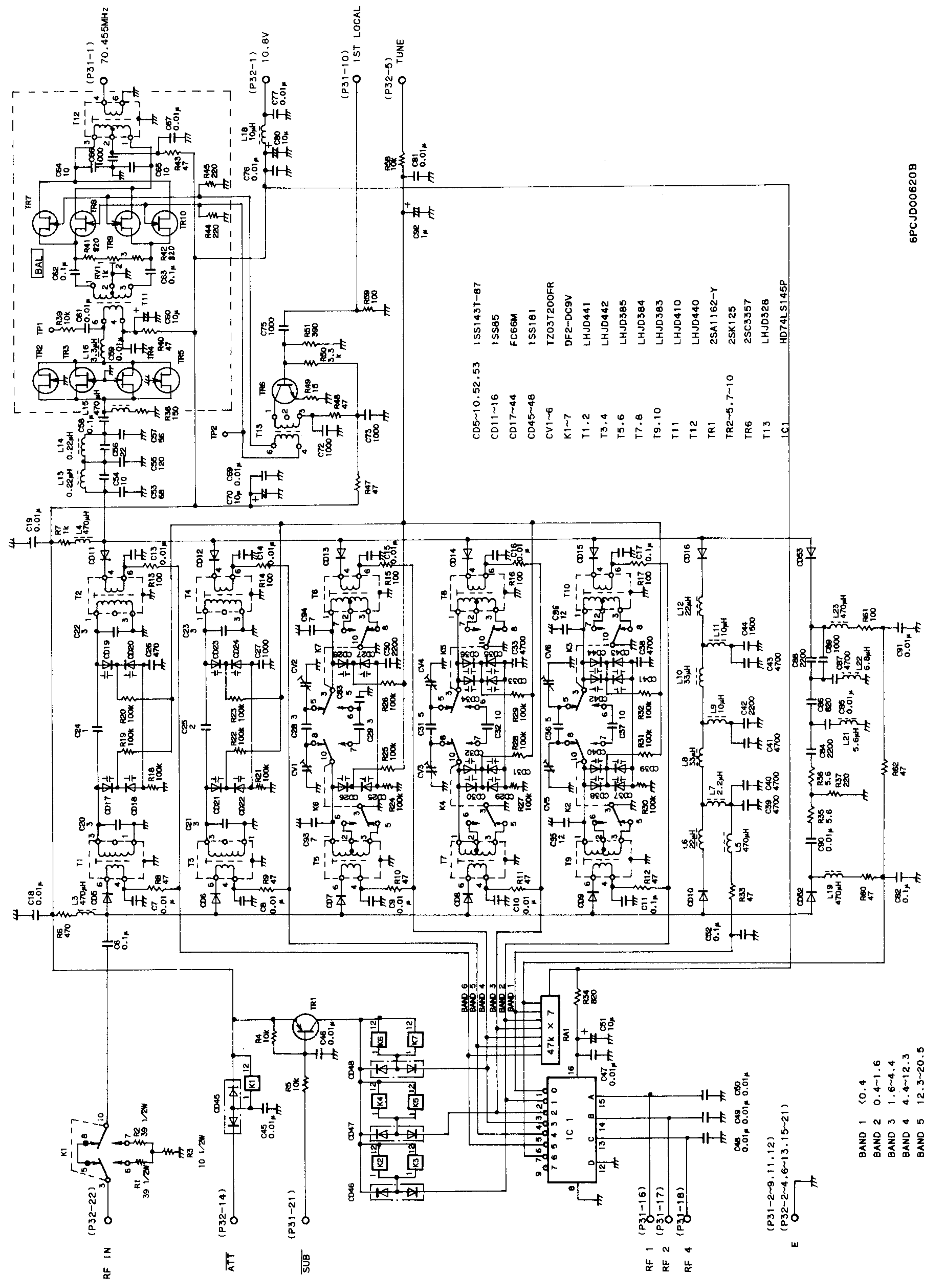

6PCJD00620B

CFH-36A IF FILTER UNIT

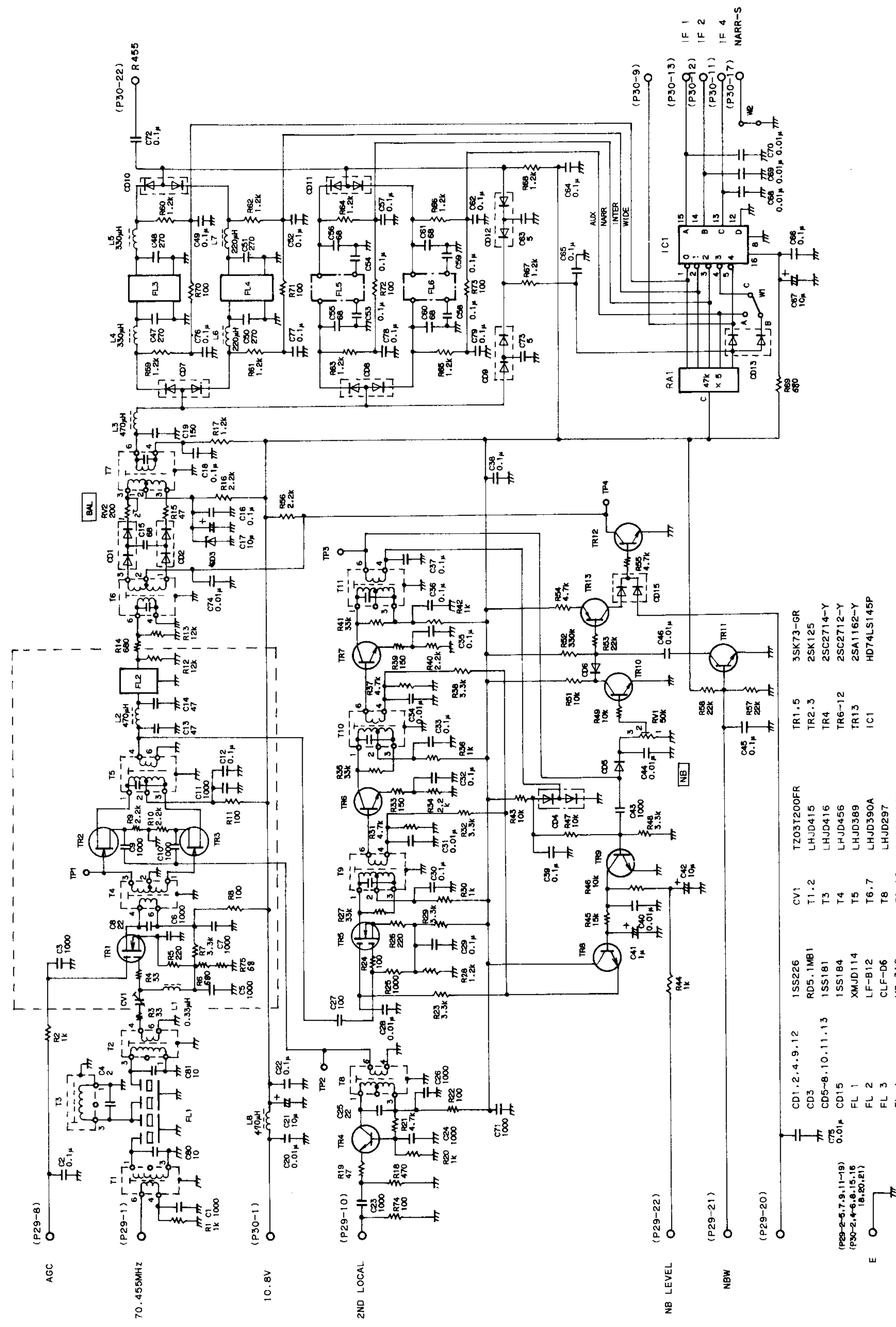

6PCJD00159B

CV1	1SS226	CD1-2,4,9,12	TR1.5	3SK73-GR
CV2	RD5.1MB1	CD3	TR2.3	2SK125
CV3	1SS181	CD4	TR4	2SC2714-Y
CV4	1SS184	CD5-8,10,11,13	TR6-12	2SC2712-Y
CV5	XMJD114	CD15	TR13	2SA1162-Y
FL 1	LF-B12	FL 1	IC1	HD74LS145P
FL 2	CLF-D6	FL 2		
FL 3	MF-31C	FL 3		
FL 4	OPTION	FL 4		
FL 5.6		FL 5.6		

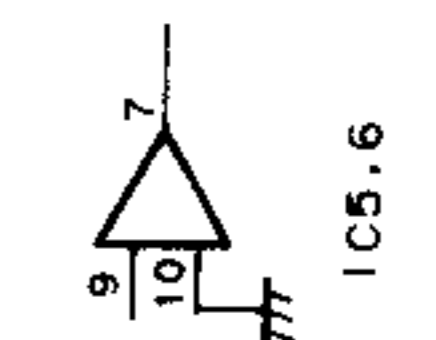
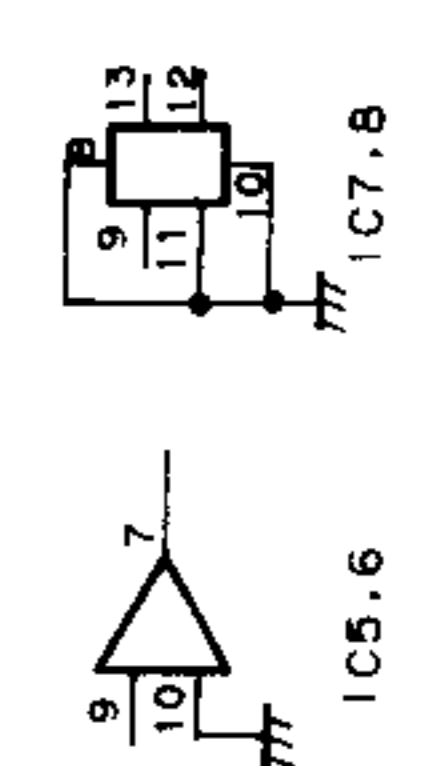
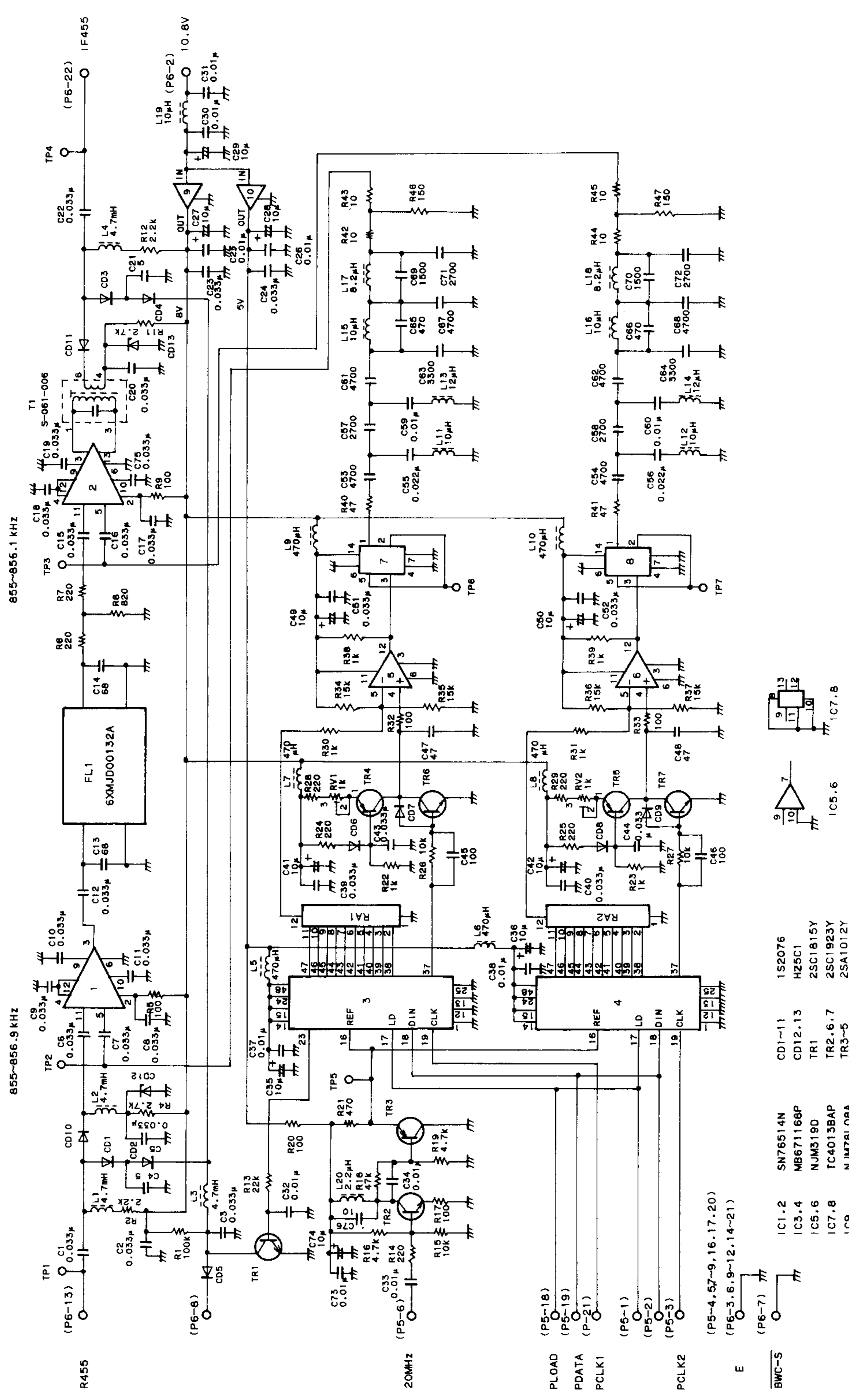

IC1.2	SN76514N	CD1~11	1S2076
IC3.4	MB671168P	CD12.13	HZ5C1
IC5.6	NJM519D	TR1	2SC1815Y
IC7.8	TC4013BAP	TR2.6.7	2SC1923Y
IC9	NJM78L08A	TR3~5	2SA1012Y
IC10	TAT7805AP	RA1.2	20B-12Z-ME5

CAE-227A IF AMP UNIT

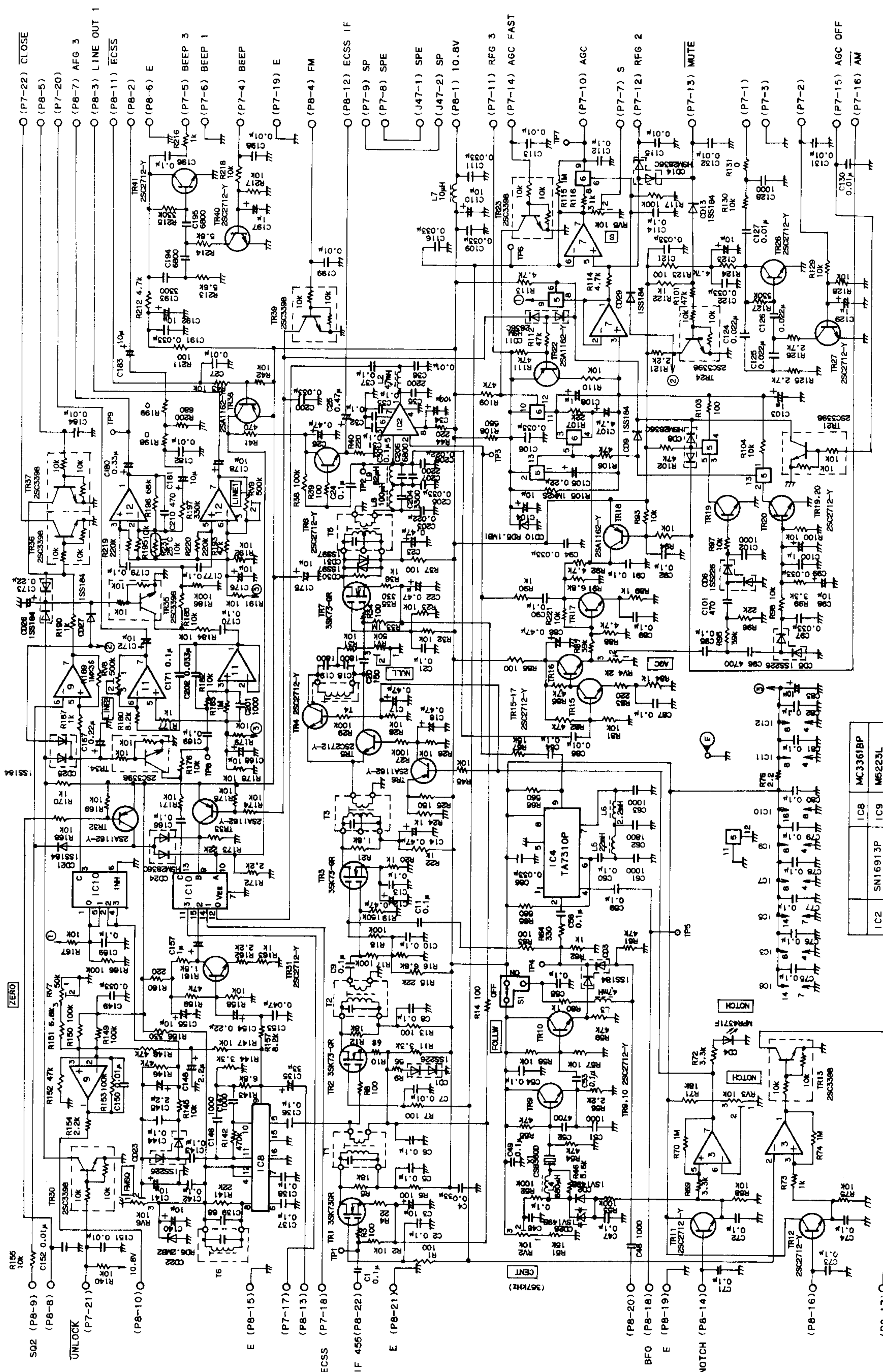

IC8	MC3361BP
IC2	SN16913P
IC3	M5223L
IC4	TA7310P
IC5	MC14068CP
IC6	MC14068CP
IC7	M5223L
IC9	M5223L
IC10	TC4052BP
IC11	M5218L
IC12	M5218L

6PCJ000260D

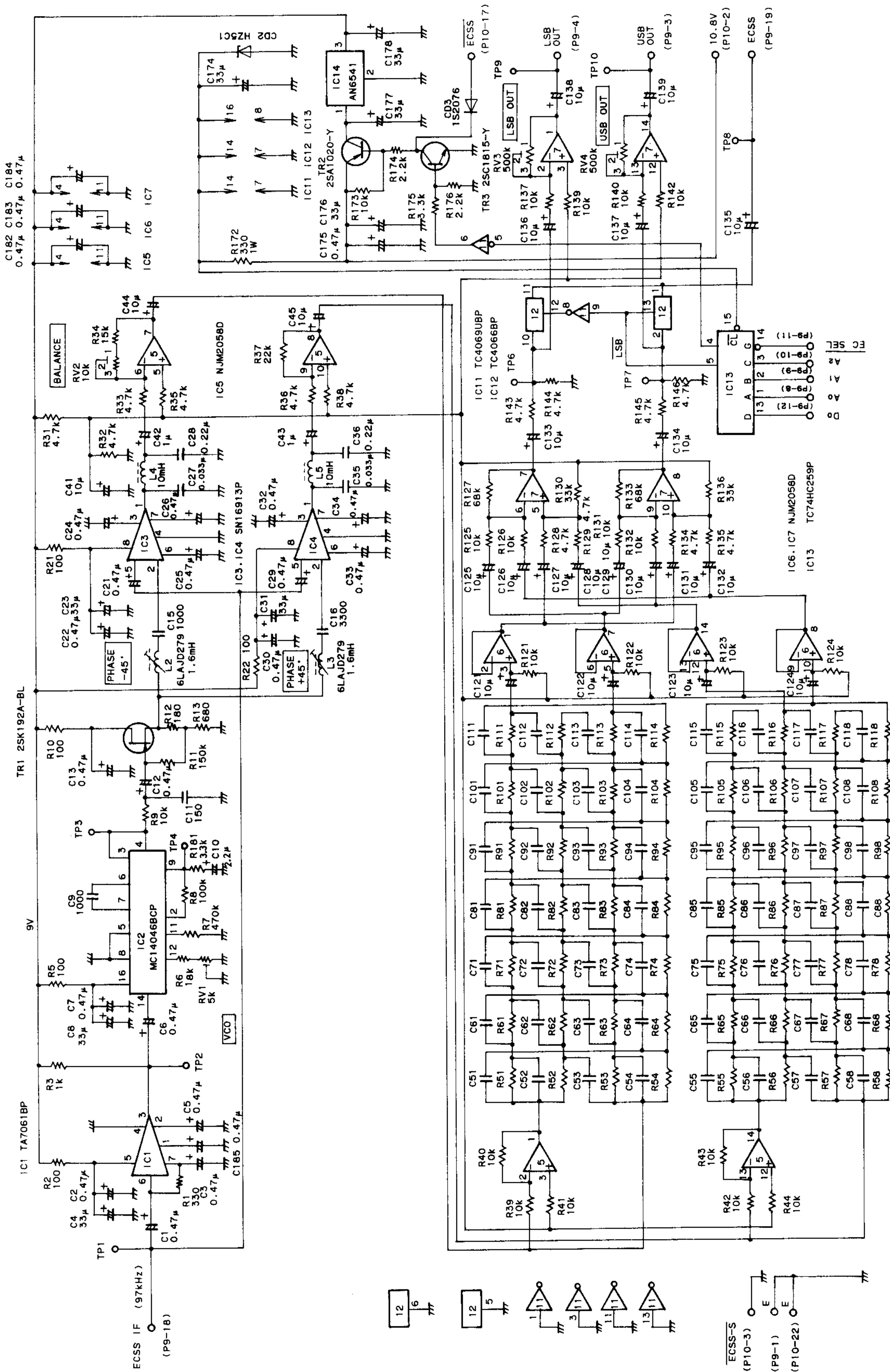

6PCJD00270A

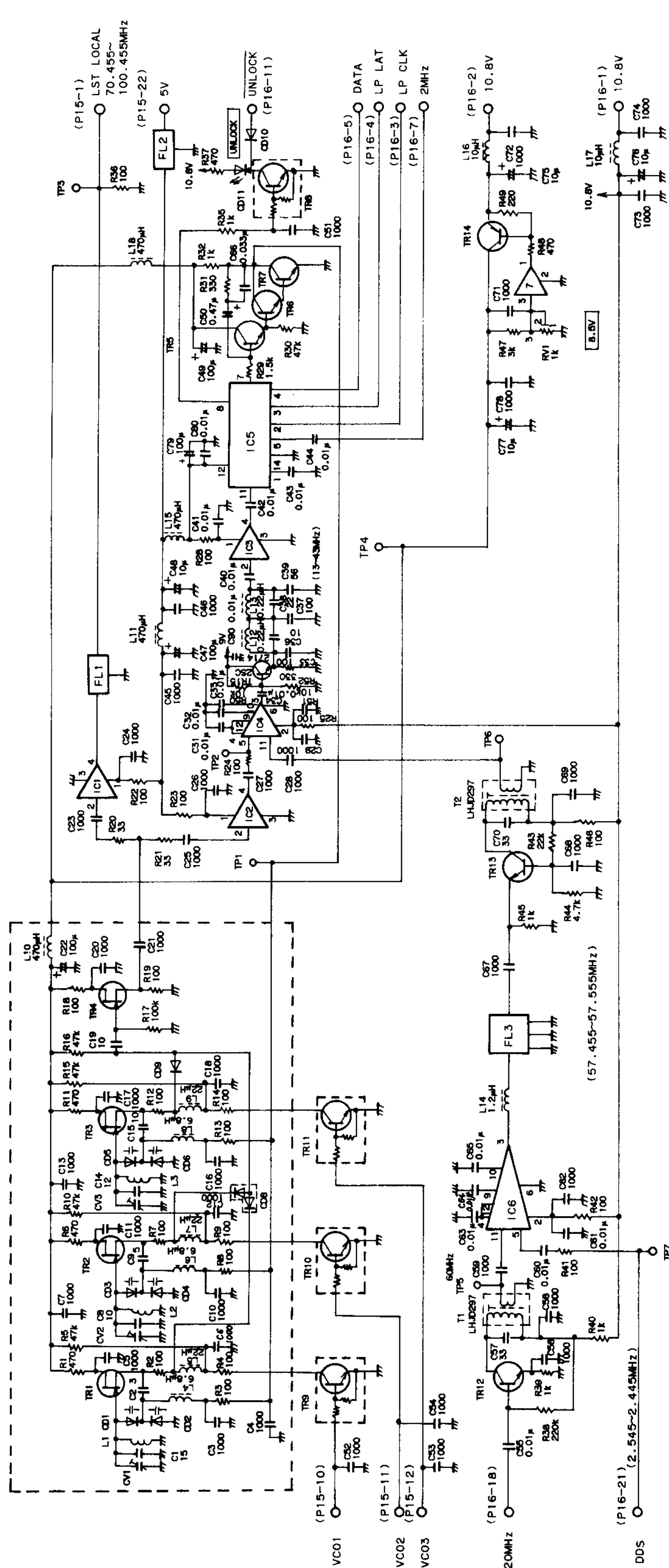

- VC01 (P15-10)
- VC02 (P15-11)
- VC03 (P15-12)
- 20MHz (P16-18)
- DDS (P16-21) (2.545-2.45MHz)
- TP7
- (P15-2-9, 13-16, 19-21)
(P16-9, 10, 12-17, 19, 20, 22)
- E
- | | | |
|----------|------------|---------------|
| CV1 ~ 3 | TZ03Z100FR | BPEB1 |
| CD1 ~ 6 | 1SV203 | DS310-55B222M |
| CD8, 9 | HSM2694 | SAF58MH70Z |
| CD10 | 1SS226 | IC1 ~ 3 |
| CD11 | MFR4371F | μPC1651G |
| TR1 ~ 4 | 2SK210-BL | IC4, 6 |
| TR5 ~ 7 | 2SC3324-GR | IC5 |
| TR8 ~ 11 | 2SC3398 | IC7 |
| TR12, 13 | 2SC2714-Y | L1 |
| TR14 | 2SA1015-Y | L2 |
| | | L3 |

6PCJD00261C

CGK-127A REF/DDS UNIT

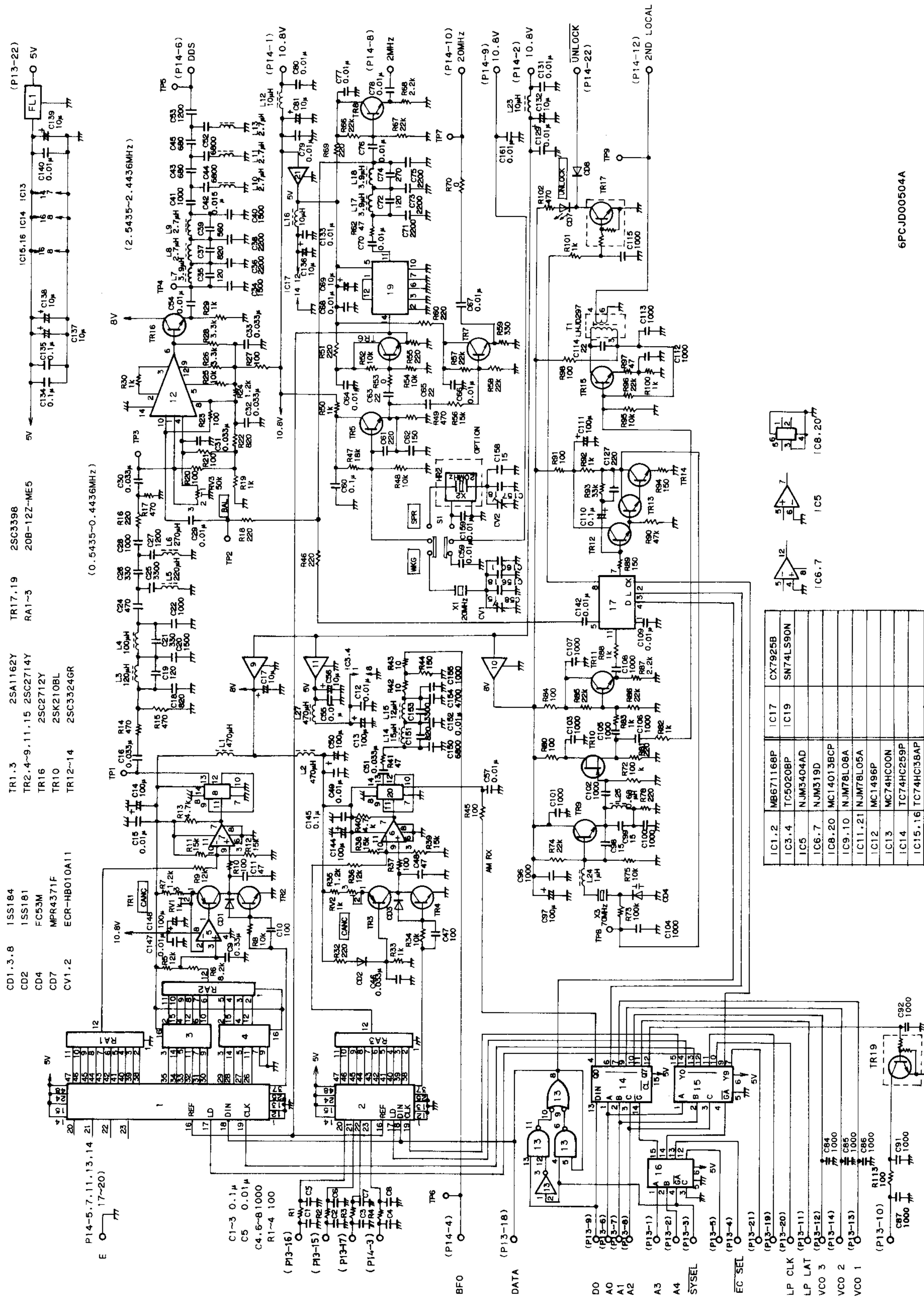

IC1.2	MB671168P	IC17	CX7925B
IC3.4	TC50208P	IC19	SN74LS90N
IC5	NJM3404AD		
IC6.7	NJM319D		
IC8.20	MC14013BCP		
IC9.10	NJM78L08A		
IC11.21	NJM78L05A		
IC12	MC1496P		
IC13	MC74HC00N		
IC14	TC74HC259P		
IC15.16	TC74HC158AP		

6PCJD00504A

CDC-493AD CPU UNIT

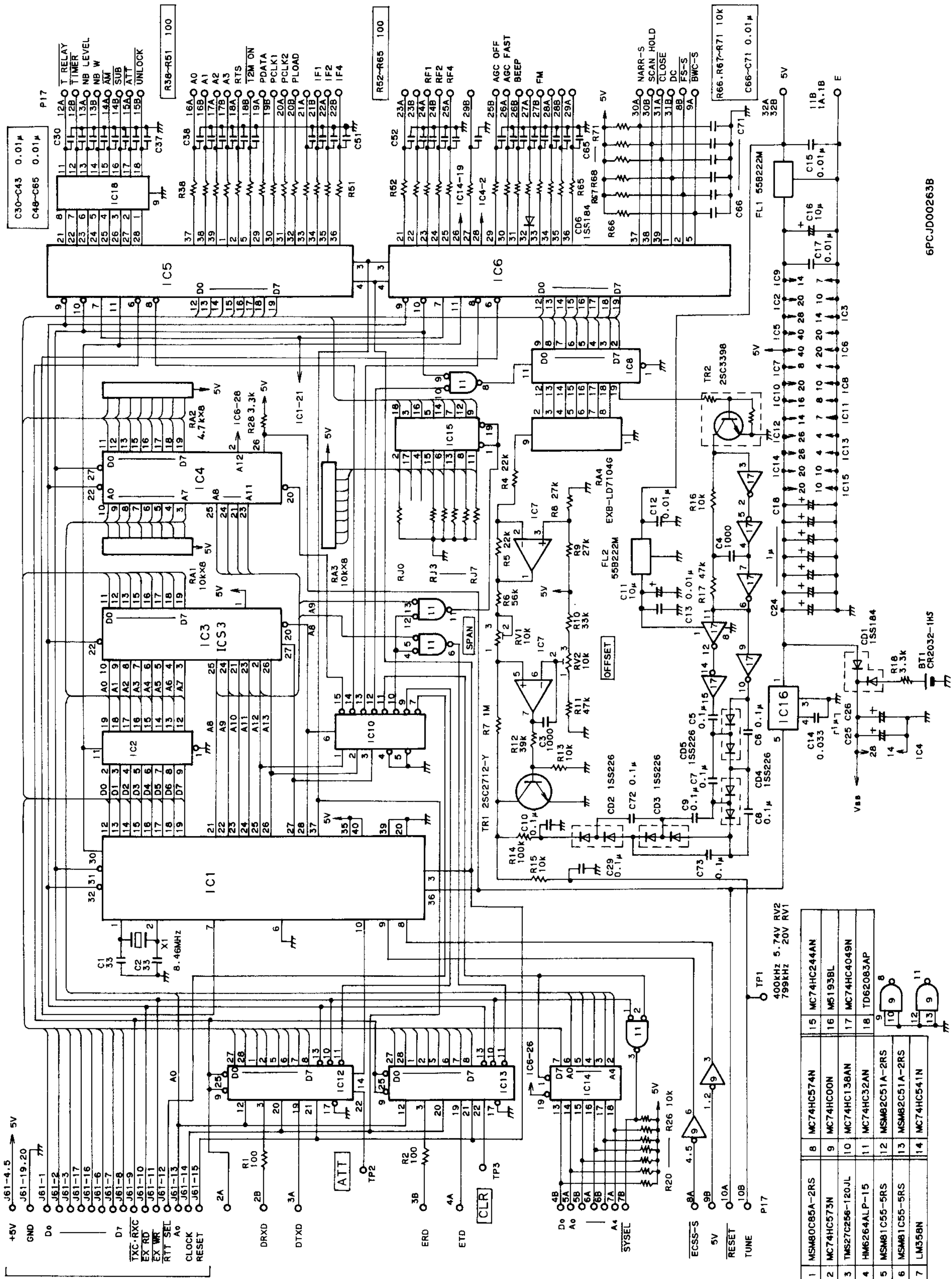

1	MSM80C85A-2RS	8	MC74HC574N	15	MC74HC244AN
2	MC74HC573N	9	MC74HC00N	16	M5193BL
3	TM527C256-120JL	10	MC74HC138AN	17	MC74HC4049N
4	HM6264ALP-15	11	MC74HC32AN	18	TD62083AP
5	MSM81C55-5RS	12	MSM82C51A-2RS	9	
6	MSM81C55-5RS	13	MSM82C51A-2RS	10	
7	LM358N	14	MC74HC541N	11	

6PCJD00263B

CMH-530 RTTY DEMODULATOR UNIT (OPTION)

RV4	2295HZ
RV5	2125HZ
RV6	1895HZ
RV7	1445HZ

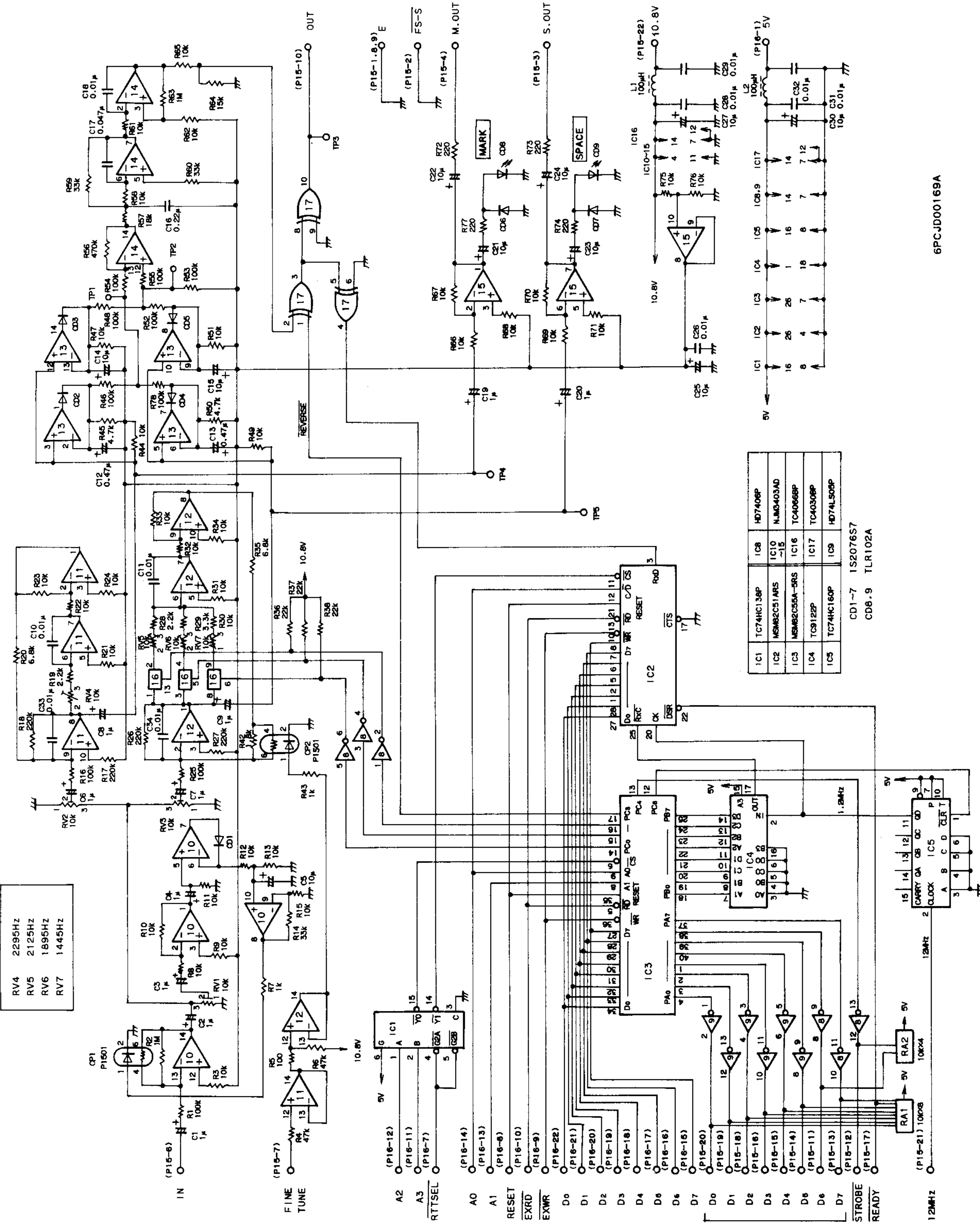

IC1	TC74HC13BP	IC8	HD7408P
IC2	MSM82CS1ARS	IC10	NJM4403AD
IC3	MSM82CS5A-SRS	IC16	TC4066BP
IC4	TC9122P	IC17	TC4030BP
IC5	TC74HC160P	IC9	HD74LS08P

CD1-7 1S2076S7
CD8-9 TLR102A

6PCJD00169A

CDE-705 DISPLAY UNIT

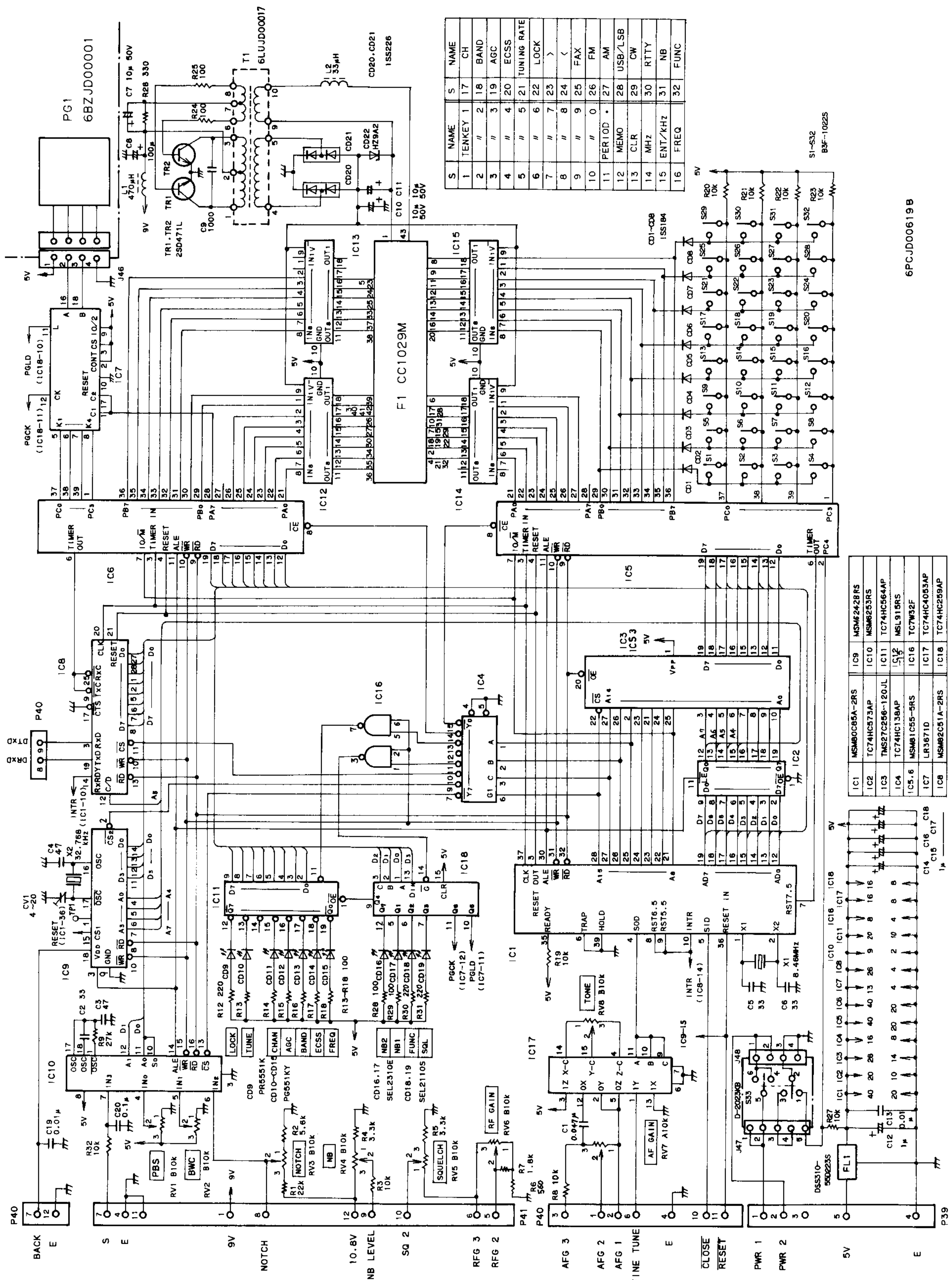

S	NAME	S	NAME
1	TENKEY	17	CH
2	"	18	BAND
3	"	19	AGC
4	"	20	ECSS
5	"	21	TUNING RATE
6	"	22	LOCK
7	"	23	>
8	"	24	<
9	"	25	FAX
10	"	26	FM
11	PERIOD	27	AM
12	MEMO	28	USB/LSB
13	CLR	29	CW
14	MHZ	30	RTTY
15	ENT/KHZ	31	NB
16	FREQ	32	FUNC

IC1	MSM62428 RS	IC9	MSM6253RS
IC2	TC74HC573AP	IC10	MSM6253RS
IC3	TMS27C256-120JL	IC11	TC74HC564AP
IC4	TC74HC13BAP	IC12	MSL915RS
IC5.6	MSM81C55-5RS	IC16	TC7W32F
IC7	LR3871D	IC17	TC74HC4053AP
IC8	MSM82C51A-2RS	IC18	TC74HC259AP

6PCJD00619B

S1-532
B9F-10225