

# SOMMERKAMP<sup>®</sup>

## CITIZENS BAND TRANSCEIVER INSTRUCTION MANUAL



MODEL: TS-664S

## CONTROL LOCATIONS:

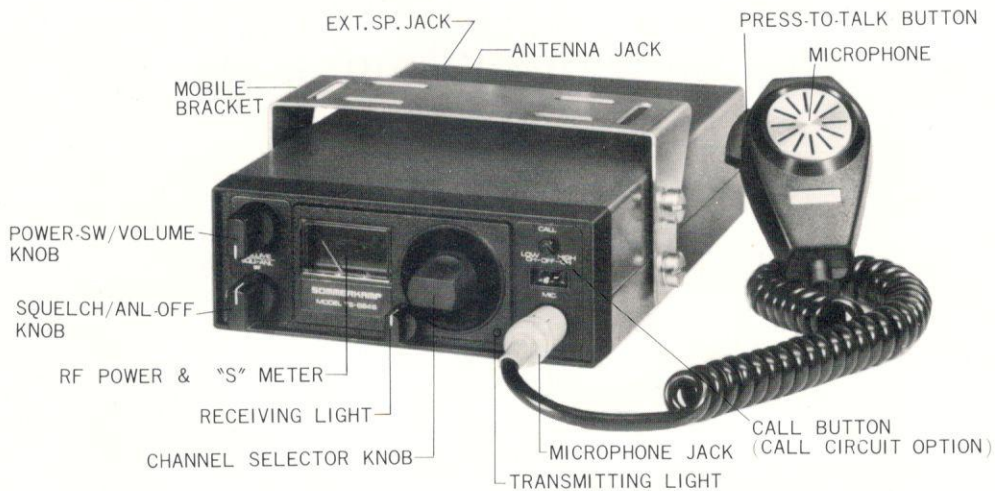

## PACKING LIST

Beside this manual, the carton shall contain the following items:

1. Transceiver TS-664S.
1. Mounting bracket.
4. Screw for Mounting bracket.
1. Microphone hanger.
1. Microphone.

## GENERAL DESCRIPTION

Your SOMMERKAMP TS-664S transceiver has been designed for continuous heavy duty mobile and base station application.

It can be operated with a microphone and internal speaker or handset, speaker/microphone combination, telephoneset incorporating automatic voice operated transmit/receive switching, external selective calling with automatic answer-back and many more.

## GENERAL

The transceiver is designed to operate from 12 Volt DC powersupply as a base or mobile station. It's straight forward 64 channel capability allows it to operate on any channel within 26.965 and 27.595 MHz.

## RECEIVER SECTION

The receiver section is designed to receive amplitude modulated (AM/A3) signals in the 26.965 to 27.595 MHz. (11 meter) citizens band.

The unique combination of low noise Field Effect Transistor (FET), double conversion, a combination of mechanical ceramic, and L/C filters, fully automatic noise limiter (ANL) and a hifi quality speaker amplifier will give you exceptional reception quality in this fine piece of equipment.

In addition, the above combination of the latest technology provides you with a sensitivity and unwanted signal rejection and noise suppression available previously only in space and military communication equipment.

The power supply of the receiver RF, IF, and oscillator section is stabilized by an extreme sharp cut-off Zener diode to obtain the high sensitivity and unwanted signal rejection. The fully automatic series gate noise limiter, which virtually cuts off the audio output during ignition noise pulses, is defeatable to make even the weakest signal audible which otherwise would be cut off by the threshold level of the ANL switching diode.

The high squelch sensitivity is achieved by using a separate squelch detector and switching circuit with a carefully balanced hysteresis. The transformerless hifi quality audio power amplifier will drive any load between 8 ohms and indefinite such as internal speaker or external speaker/microphone or headset combinations having the above impedances.

The meter indicates the field strength during reception of a signal.

## **TRANSMITTER & MODULATOR SECTION:**

The transmitter section is designed for continuous heavy duty transmission of amplitude modulated (AM/A3) signals in the 26.965 to 27.595 MHz. (11 meter) citizens band.

The transmitter consists of 2 crystal controlled oscillators incorporating 20 crystals. The output of these oscillators are synthesized in a class B mixer, followed by a double tuned filter, Class AB1 buffers, and a highly efficient collector-modulated class C driver and power output stage, coupled by series and pi-matching filters to the antenna jack.

The modulator consists of an input audio filter, ALC amplifier integrated pre- and power amplifier and modulation transformer. This gives you the lowest possible modulation distortion and up to 100% modulation.

The input is designed for 500 ohm dynamic microphone or 32 ohm speaker/microphone combination with a 1K ohm resistor in series.

## **RECEIVE/TRANSMIT SWITCHING**

The receive/transmit switching is done by a single pole, single throw switch in the microphone and a combination of NPN and PNP switching transistors.

## **METER**

The combination meter provides you with the following functions:

During receive mode.....it indicates the incoming signal strength.

During transmit mode..... it indicates the output power.

## **MOBILE INSTALLATION**

Mounting bracket and screws are supplied for mounting the transceiver underneath the dashboard. Microphone hanger and screws are also supplied. For electrical connection, first make sure that the transceiver is turned off. Connect the red wire to the ACC terminal of the ignition switch or + terminal of battery and ground the black wire to the chassis of the vehicle. The black wire should be grounded as short as possible to minimize noise interference. This transceiver is designed for use with the negative ground system.



Connect the antenna plug to the antenna jack with an SWR-Meter inserted into the antenna cable.

Connect the microphone to the microphone jack.

Switch the transceiver ON.

The receiving, meter and the channel lamp, shall light up.

Turn the squelch control to min. (ANL OFF)

Tune the Volume control to max. Until you hear a rushing sound from the speaker.

Switch the channel selector to CH. 1.

Push the transmit button on the microphone and check with the SWR-Meter Immediately the SWR of your antenna.

The SWR must be less than 1 to 2. Do this within 3 seconds, because if the SWR is higher than 1 to 2 it is very likely that the transmitting transistors will be damaged if you operate the transmitter too long with a antenna having a too high SWR. Also read carefully the recommendations on antennas.

NOTE: In case the SWR is too high, the Automatic protection circuit will switch off the transmitter.

If the SWR is less than 1 to 2 continue checkout. if it is more than 1 to 2 repair or replace your antenna.

Check that the meter needle is near the red mark during transmitting. Talk into the microphone. The meter needle shall move a little. Release the transmit button and switch the channel selector to channel 1,2 etc. until you receive a station.

Wait until this station stops to transmit and turn the Squelch control slowly to max. Until the background noise just disappears. When the station starts to transmit again, you will hear this station, but you will not hear the background noise during non transmitting periods.

## **OPERATING INSTRUCTONS**

The transceiver is ready to operate when it is installed with an antenna properly connected. Note that the communication range differs depending upon the environment where the transceiver is operated.

You may reach 30 or 40 kilometers where no obstacle exists, but the range may be limited to 5 or 6 kilometers in cities where many high buildings disturb the communication.

- 1) Turn the set on by switching the LOW CH-OFF-HIGH CH. snap switch to the desired channel range and the channel dial will be lighted. Turn the volume control clockwise to increase the audio sound. Note that the volume control knob is only for adjusting the audio volume, not to increase the transmitting power.
- 2) Set the DELTA-TUNE for best reception.
- 3) Turn the squelch control clockwise until incoming noise is eliminated. Do not turn it excessively as the sensitivity may be reduced.
- 4) Turn the squelch control counter-clockwise to switch off the ANL (Automatic Noise Limiter).
- 5) Turn the channel selector knob to the desired channel.
- 6) For transmitting, press the button on the microphone and speak into it normally. Release the button for receiving.

## **METER**

The meter reading indicates the signal strength at receiving, and functions as an output indicator at transmitting, and the meter pointer should be within the red zone under the normal conditions.

## **CIRCUIT PROTECTION INDICATION LAMP**

The lamp is on when the antenna is mismatched, and the transmitting circuit will be cut off.

## LIST OF CHANNEL FREQUENCIES

CH. NO.	LOW CH. (MHz)	HIGH CH. (MHz)	CH. NO.	LOW CH. (MHz)	HIGH CH. (MHz)
1	26.965	27.285	14	27.125	27.445
2	26.975	27.295	15	27.135	27.455
3	26.985	27.305	C	27.145	27.465
A	26.995	27.315	16	27.155	27.475
4	27.005	27.325	17	27.165	27.485
5	27.015	27.335	18	27.175	27.495
6	27.025	27.345	19	27.185	27.505
7	27.035	27.355	D	27.195	27.515
B	27.045	27.365	20	27.205	27.525
8	27.055	27.375	21	27.215	27.535
9	27.065	27.385	22	27.225	27.545
10	27.075	27.395	E	27.235	27.555
11	27.085	27.405	F	27.245	27.565
11A	27.095	27.415	23	27.255	27.575
12	27.105	27.425	G	27.265	27.585
13	27.115	27.435	24	27.275	27.595

# MICROPHONE JACK

The 7-pin DIN standard accessory jack has the following internal connections:

1. Microphone input (Z 600-10K ohm)
2. Transmit/Receive switching.
3. Internal microphone output (Z 1K ohm)
4. Internal speaker (Z 8 ohm)
5. Audio output (Z 8 ohm-10K ohm)
6. +12V for VOX unit etc.
7. Ground return for 1-6.

Always operate the transceiver with the microphone plug inserted in the microphone jack, or with the following external connections:

## 1. Microphone with VOX.

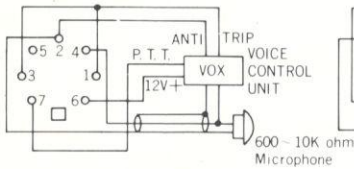

## 2. Headset or Telephoneset with PTT.

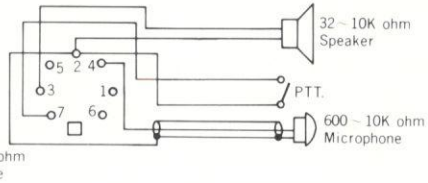

## 3. External microphone

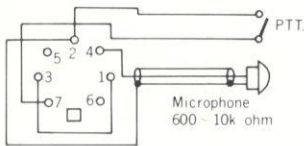

## 4. Headset or Telephoneset with VOX



## 5. External microphone/speaker with PTT.

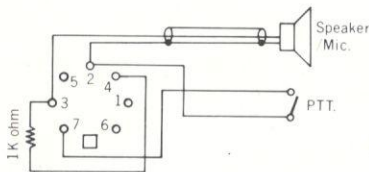

## 6. Internal connection

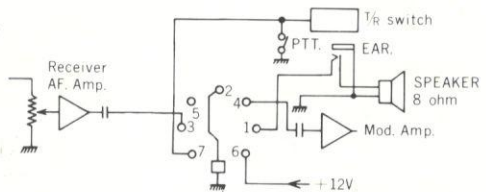



# PRINTED CIRCUIT BOARD PARTS LAYOUT

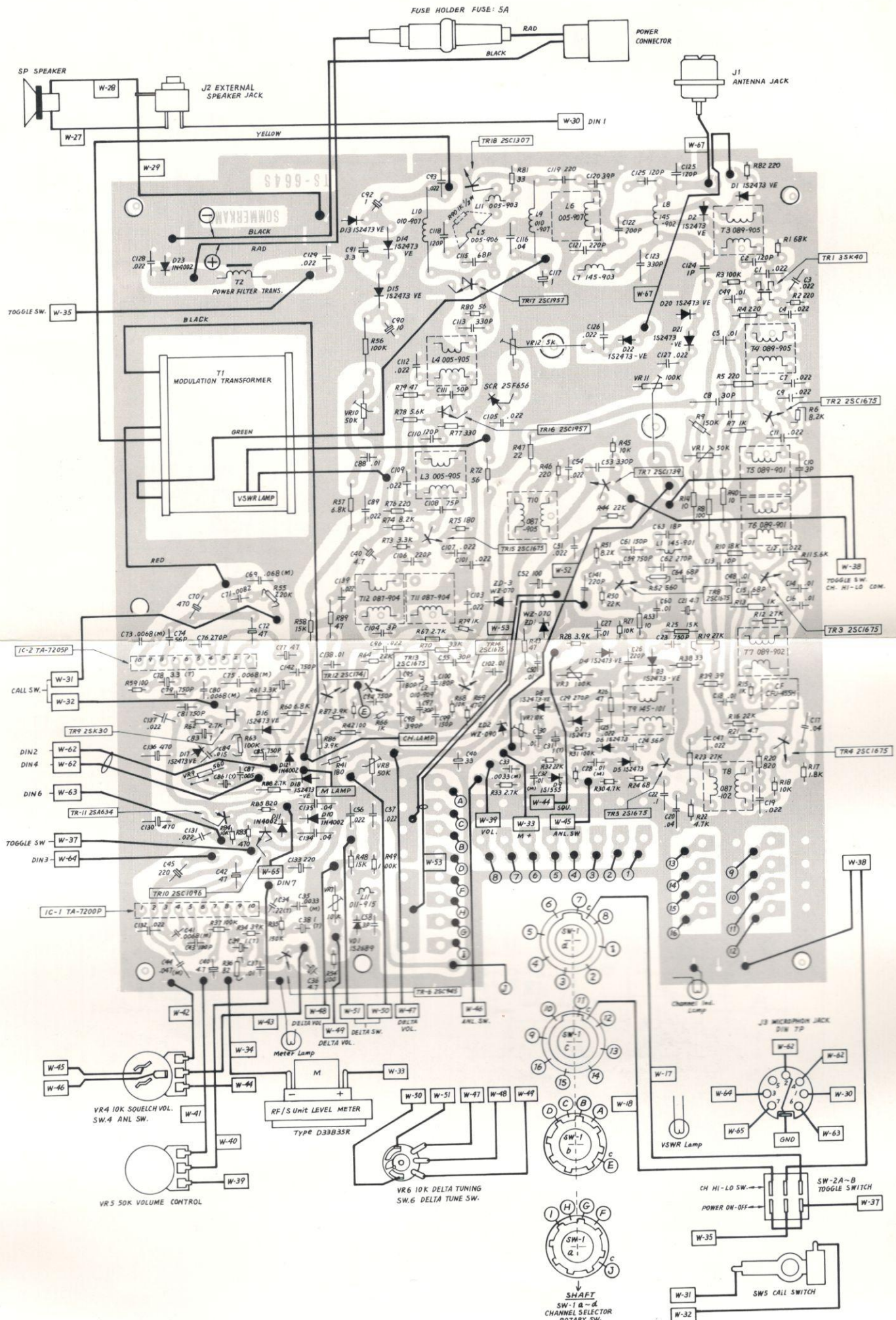



# BLOCK DIAGRAM

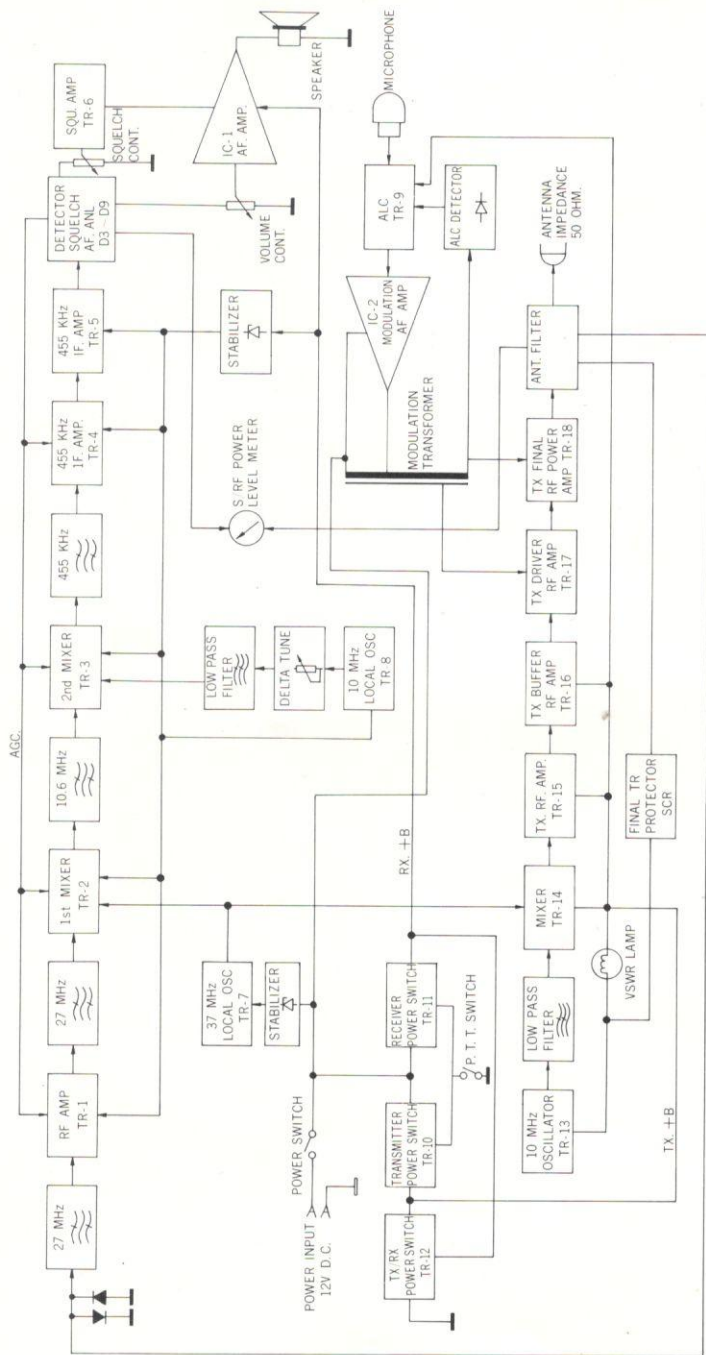

## PARTS LIST for TS-664S

DESIGNATION	PARTS NAME	PARTS NO.
MP-201	Front Frame.	483014-S
MP-202B	Chassis Frame.	502035
MP-203B	Back Pannel.	504327
MP-105	Cabinet Cover (Upper).	483016
MP-124	Cabinet Cover (Lower).	502034
MP-107	Mounting Bracket.	484085
MP-303	Front Plate (L).	494187-L
MP-304	Front Plate (R).	494187-R
MP-360	Brand Plate.	504326
MP-361	Back Plate.	504327
MP-110	Mounting Bracket for Meter.	484064
MP-208	Mounting Bracket for Output Transformer.	484080
MP-362	Heatsink for IC.	504300
MP-353	Heatsink for 2SC1237 (2SC1307) A.	494251
MP-354	Heatsink for 2SC1237 (2SC1307) B.	494252
MP-211	Meter Lamp Reflection plate.	484063
MP-212	Channel Indicator Screen.	484107
MP-214	Mounting Bracket for Channel Lamp.	484108
MP-111	Call Switch Contact.	484086
MP-112	Call Switch Spring.	484087
MP-307	Knob for Delta tune Control.	494199
MP-117	Knob for Channel Selector.	484116
MP-17	Knob for Vol./Squ. Control.	474011
MP-118	Nut for Channel Selector.	484073
MP-120	Screw for Mounting Bracket.	484098
MP-363	Channel Indicator Plate.	504325
MP-356	Heatsink for 2SC495 (2SC1957).	494250
MP-19	Call Button.	484056
MP-5	Mounting Bracket for Speaker.	474038
MP-109	Supporter for MIC. Consent.	484084
J2	EXT. Speaker Jack.	SJ-296
J1	Antenna Jack.	MRM/INCH
J3	Microphone Jack DIN Type 7P.	CS279



## PARTS LIST for TS-664S

DESIGNATION	PARTS NAME	PARTS NO.
EP-201	Power Cord with Contact & Fuse holder.	W-002
F1	Fuse 5A.	F-5A
M	Meter.	D33B35R
SP	Speaker.	SP-70-8
PL1~4	Pilot lamp 14V-80mA.	PL-14-80
SW1	Channel Selector Rotary Switch.	S32C-4632
SW2	Toggle switch.	8A-2021
MIC	Microphone Complete.	22-256-28
EP-202	Socket for Crystal unit 8P.	XS-8P
EP-203	Socket for Crystal unit 4P.	XS-4P
IC1	Integrated Circuit.	TA-7200P
IC2	Integrated Circuit.	TA-7205P
TR1	FET.	3SK-40
TR9	FET.	2SK-30A
TR18	Transistor.	2SC1307
TR16, 17	Transistor.	2SC1957
TR. 2. 3. 4. 5. 8. 13. 14. 15	Transistor.	2SC1675
TR10	Transistor	2SC1096
TR7	Transistor.	2SC1739
TR12	Transistor.	2SC1741
TR11	Transistor.	2SA634
TR6	Transistor.	2SC945
SCR	SCR.	2SF656
D9	Silicon Diode.	1S1555
VD1	Varicap Diode.	1S2689
D23, 10, 11, 12	Silicon Diode.	1N4002
D1~8, 13~18, 20~22	Silicon Diode.	1S2473VE
ZD1, 3	Zener Diode.	WZ-070
ZD2	Zener Diode.	WZ-090
T1	Modulation Transformer.	EI-54-664S
T2	Power Filter Choke Transformer.	EI-24-732P
CF	Ceramic Filter.	CFM-455H

## SPECIFICATIONS for TS-664S

Semiconductors:	2 Integrated Circuits, 2 FET, 16 Transistors. 1 SCR, 22 Silicon diode. 1 Varicap, 3 Zener diode.
Transmitter System:	Synthesized Crystal controlled. Collector modulation AM.
Frequency:	64 Channels on 27 MHz.
Input Power:	10 Watts at 13.8V DC.
Band Width:	8 KHz. (max.)
Antenna impedance:	50-52 ohms.
Receiver System:	Duble conversion superheterodyne, crystal controlled.
Sensitivity:	1 $\mu$ V or better for 100mW output, 10 dB signal to noise ratio.
Intermediate Frequency:	1st I. F. 10.7MHz, 2nd I. F. 455KHz.
Receiver Selectivity:	40 dB down at 10 KHz. or more.
Squelch Sensitivity:	2 $\mu$ V.
Audio Output Power:	2 watts in 10% distortion.
Power Source:	11~16V D. C. Negative Ground. Fuse 5A.
Microphone:	Dynamic type with press-talk switch. Impedane 500 ohm.
Speaker:	Dynamic type, Voice coil Impedans 8 ohm.
Size:	156 $\times$ 58 $\times$ 205 mm.
Weight:	2.3 kg.
Accessories:	Mounting bracket, Mounting hardware, power cord.

**SOMMERKAMP ELECTRONIC SAS**

CH-6903 LUGANO, P.O. BOX 176

SWITZERLAND

TEL.91 688543 TELEX:79314