

# SOMMERKAMP

**MODEL TS-788DX**

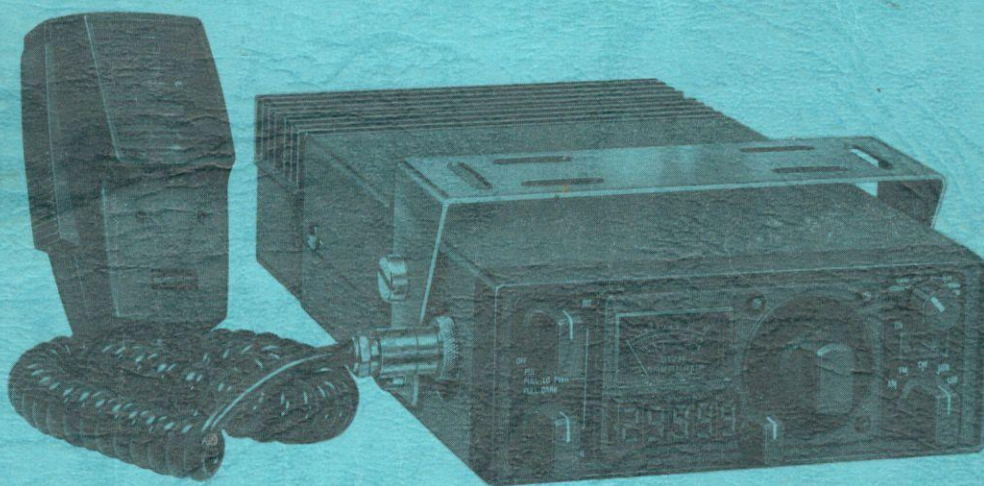

**INSTRUCTION MANUAL**

## TABLE OF CONTENTS

I.	SPECIFICATIONS .....	1
II.	GENERAL DESCRIPTIONS .....	2
III.	INSTALLATIONS .....	3
IV.	CONTROLS & FUNCTIONS .....	6
V.	OPERATIONS .....	11
VI.	CIRCUIT DESCRIPTIONS .....	12
VII.	MAINTENANCE & ALIGNMENTS .....	17
VIII.	DIAGRAMS & LAYOUTS .....	23
IX.	PARTS LIST .....	36

## SECTION I - SPECIFICATIONS

### GENERAL:

1. Semiconductors : 31 IC's, 41 Transistors, 2 FET's & 119 Diodes.
2. Frequency Range : 26.000—29.999MHz
3. Modes of Operation : AM, FM, LSB, USB & CW
4. Speaker : Dynamic type, 8 ohm.
5. Microphone : Ceramic type
6. Power Supply : 11V—16V DC, negative ground.
7. Antenna Impedance : 50 ohm.
8. Size : 61×156×290mm

### RECEIVER:

1. Receiver System : Single Conversion PLL Superheterodyne.
2. Sensitivity at S/N 10dB : AM .....0.75 $\mu$ V  
: FM .....0.75 $\mu$ V  
: SSB.....0.25 $\mu$ V
3. Selectivity : AM .....6KHz at Bandwidth—6dB.  
: FM .....6KHz 60dB down at 8 KHz  
: SSB.....2.4KHz at Bandwidth—6dB
4. AGC Figure of Range : 80dB. 60dB down at 4.8KHz
5. Squelch Range : 1 $\mu$ V—100 $\mu$ V.
6. Audio Output Power : 2.5 Watts
7. Spurious Response : -60dB.
8. I.F. : 10.7MHz.

### SSB TRANSMITTER:

1. RF Output Power (max) : 100 Watts PEP.
2. Carrier Suppression : More than 50dB.
3. Unwanted Sideband Suppression : More than 60dB.
4. Harmonic Suppression : More than 60dB.

### FM TRANSMITTER:

1. RF Output Power (max) : 100 Watts
2. Deviation :  $\pm$ 1.5KHz.
3. Harmonic Suppression : More than 60dB.

### AM TRANSMITTER:

1. RF Output Power : 25 watts carrier
2. Modulation Capability : More than 80%
3. Harmonic Suppression : More than 50dB.

### ACCESSORIES:

A packing will contain the following accessories beside the Model TS-788DX:

- 1) Car mounting bracket ..... 1 pce.
- 2) Mounting screw (large) ..... 4 pcs.
- 3)     "             " (middle) ..... 4   "
- 4)     "             " (small) ..... 2   "
- 5)     "             nut ..... 4   "
- 6) Various washer ..... 10   "

## SECTION II - GENERAL DESCRIPTIONS

Your SOMMERKAMP TS—788DX transceiver has been designed for continuous heavy duty mobile and base station application on AM, FM, LSB(Lower Single Side Band), USB (Upper Single Side Band) and CW (Morse Key).

The biggest feature of this transceiver is the continuous coverage on entire frequencies between 26.000MHz and 29.999MHz.

One more special feature of your TS-788DX is that you can operate this transceiver with the remote control microphone by which you can control frequency selection, volume, clarifier and scanner.

This transceiver is designed to operate with a 13.8V DC power supply as a base station or mobile station.

The receiver section is designed to receive either AM/A3, FM/F3, SSB/A3J and CW /A1 signals in the 26.000 to 29.999MHz band.

The unique combination of low noise Field Effect Transistors (FET), a combination of ceramic filters and crystal filter, efficient noise limiter (ANL) and a HiFi quality speaker amplifier will give you exceptional reception quality.

In addition, the above combination of the latest technology provides you with a sensitivity and unwanted signal rejection and noise suppression available previously only in space and military communication equipment.

Power supply of the receiver RF, IF and oscillator section is stabilized by an extreme sharp cut-off Zener diode to obtain the high sensitivity and unwanted signal rejection. The efficient series gate noise limiter, which virtually cuts off the audio output during ignition noise pulses, is defeatable to make even the weakest signal audible which otherwise would be cut off by the threshold level of the ANL switching diode. The high squelch sensitivity is achieved by using a separate squelch detector and switching circuit with a carefully balanced hysteresis.

The transformerless HiFi quality audio amplifier will drive any load between 8 ohms and indefinite such as internal speaker or external speaker/microphone or headset combinations having the above impedances.

An automatic tuning circuit will automatically tune to the best reception on the entire band.

The transmitter section is designed for continuous heavy transmission of either AM /A3, FM/F3, SSB/A3J and CW/A1 signal in the 26.000 to 29.999 MHz band. The transmitter consists of a Phase-Locked Loop circuit and one crystal controlled oscillator, of which output is synthesized in a balance mixer followed by a double tuned filter, class AB1 buffers, auto-tune circuit and power output stage, coupled by series and pi-matching filters to the antenna jack.

Modulator is consisted of an input audio filter, audio pre-amplifier, ALC amplifier and audio buffer followed by balance modulator AM and SSB, or VCO for FM. The input is designed for 1K ohm ceramic microphone, 500 ohm dynamic microphone or 32 ohm speaker/microphone combination with a 1K ohm resistor in series.

## SECTION III - INSTALLATIONS

### UNPACKING:

Carefully remove your transceiver from the packing carton and examine it for signs of shipping damage. It is recommended you keep the shipping cartons. In the event storage, moving, or reshipment becomes necessary, they come in handy. Accessory hardware, screws, etc. are packed with the transceiver. Make sure you have not overlooked anything.

### LOCATION:

The transceiver should be mounted where there is adequate space around the heatsink fins to allow free air circulation.

Mounting bracket and screws are supplied with the transceiver. For electrical connection, first make sure if the transceiver is turned off.

### POWER REQUIREMENT:

The transceiver is supplied ready to operate from any regulated 13.5 VDC, 15 ampere negative ground source. An automobile, 12 volt negative ground system is usually more than adequate. Some note must be taken, however, to the condition of the vehicle's electrical system. Items such as low battery, worn generator/alternator, poor voltage regulator, etc. will impair operation of your transceiver as well as the vehicle. High noise generation or low voltage delivery can be traced to these deficiencies. If an AC power supply is used with your transceiver, make certain it is adequately regulated for both voltage and current. Low voltage while under load will not produce satisfactory results from your transceiver. Receiver gain and transmitter output will be greatly impaired.

**CAUTION:** Excessive Voltage (above 15VDC) will cause damage to your transceiver. Be sure to check the source voltage before connecting the power cord.

Attached with your transceiver is a DC power cable. The Red Wire is positive (+), the Black, negative (-). If your mobile installation permits, it is best to connect these directly to the battery terminals. This arrangement eliminates random noise and transient spient spikes sometimes found springing from automotive accessory wiring. If such an arrangement is not possible, then any convenient B+ lead in the interior of the vehicle and the negative frame can be utilized. Your transceiver provides an internal DC filter that will take out the large amount of transient difficulties anyway. Remember, the unit operates on a negative ground system only-it cannot be used in a positive ground automobile.

### ANTENNA REQUIREMENT:

This transceiver can be operated with any standard 50 ohm ground-plane, vertical, mobile whip, long wire or other adequate antennas. A standard SO-239 type connector is provided on the back panel for use with popular PL-259 antenna plug. A ground-plane type will provide greater coverage, and since it is essentially non-directional, it is ideal in base station to mobile operation.

From base station to base station, or point to point operation, a directional beam will give greater distance even under the adverse conditions.

A vertical whip antenna is best suited for mobile use. A non-directional antenna must be used for best result in any case. The base loaded whip antenna will normally provide effective communication. For greater range and more reliable operation, a full quarter wave whip may be used. Either of these antennas use the metal car body as a ground-plane, and the shield of the base as well as the metal case of the transceiver should be grounded.

Do not become alarmed if your transceiver fails to transmit at times during the antenna tune up procedure. Remember, your transceiver has a built-in Automatic protection Circuit (APC) that will disable the transmitter if excessive VSWR, a shorted coaxial line or connector, or other antenna deficiency is present. A quick check on a good 50 ohm dummy load will show the transceiver to be working. The difficulty will lie with the antenna or its transmission line.

#### MICROPHONE:

A high quality special microphone is supplied with your transceiver. Merely plug it into the proper receptacle on the left side of the cabinet

The microphone supplied with the transceiver has the following functions:

1. Ceramic type microphone
2. Extension speaker
3. UP/DOWN frequency control
4. Volume control
5. Clarifier (RIT) control & mic clarifier off
6. Main speaker & microphone speaker switch

To transmit simply press the PTT bar of the microphone and release it for reception. The microphone has an auxiliary volume control which is an extension of the regular front panel receiver volume control. It offers great operating convenience by giving you instant volume adjustment right at your fingertips even while you are driving. As this is an extension control, the regular front panel volume control should be advanced in order. The same applies to the extension clarifier (RIT) control on the microphone, that means the regular front panel clarifier (RIT) should be fully advanced before using the clarifier on the microphone. By the speaker switch found on the back of the microphone, you can select the speaker being used, whether the main speaker of the set or the speaker installed in the microphone.

#### Important Hint:

For using a dynamic microphone, telephone handset or PARROT 76, simply cut off the jumper wire as next illustrated, or solder a 0.1mf capacitor across the microphone output. No function of UP/DOWN frequency control of the microphone will then be possible.



# CONTROL LOCATIONS

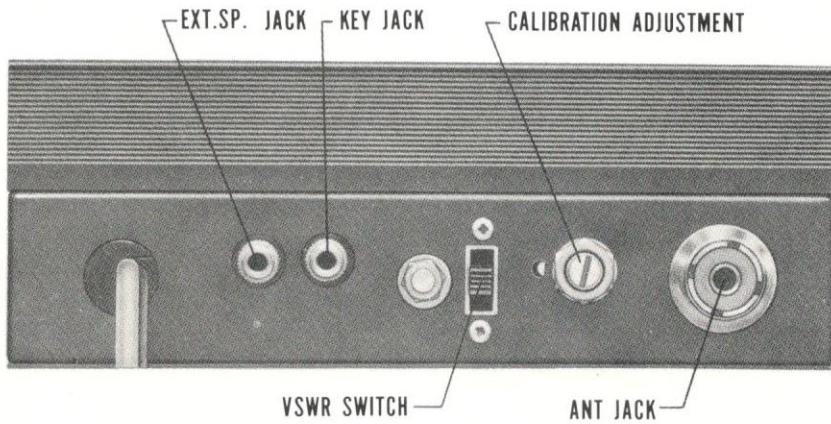
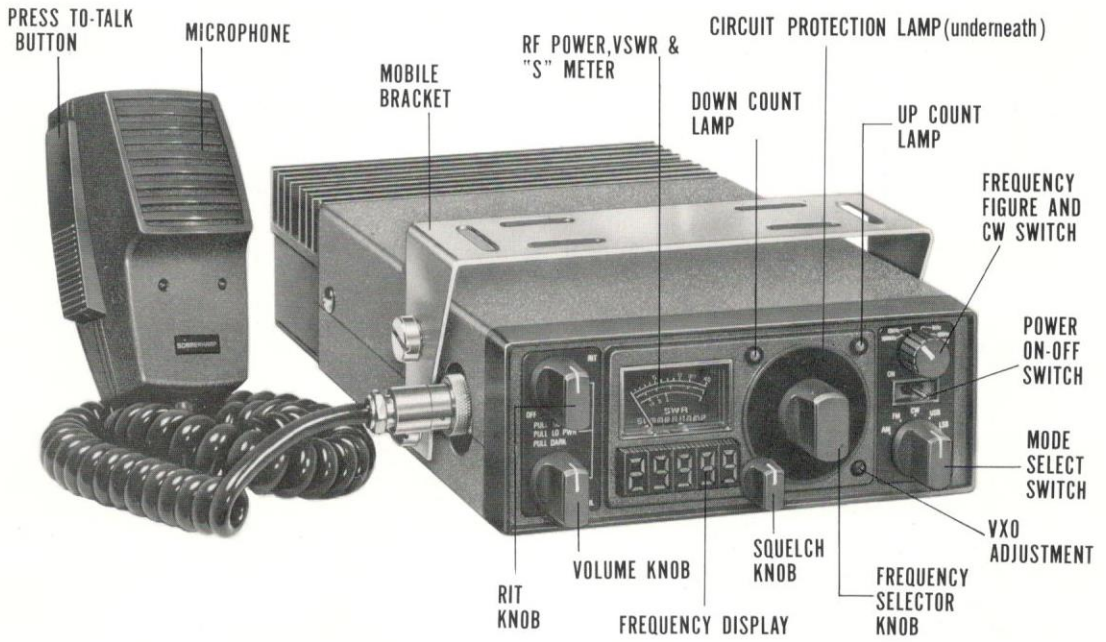

## SECTION IV-CONTROLS & FUNCTIONS

### FRONT CONTROLS

#### POWER ON-OFF SWITCH:

You can turn on the transceiver by snapping the toggle switch either to the left or right position, and off by switching it back to the center position.

By the right position, the transceiver will immediately be ready on the emergency channel of CH-9(27.065MHz) both on reception and transmission.

By the left position, the transceiver will work on from the memorized frequency you used last.

It is important to note the followings:

1. By snapping to CH-9 position, the transceiver starts immediately from 27.065 MHz.
2. And if you snap the switch to the left which is ON position, the frequency used last will be memorized and indicated again.
3. By snapping from the center OFF position to the left, it indicates always the frequency you used last.
4. And by switching again to the right to CH9 position via OFF position, it always indicates 27.065MHz.
5. However it could be possible that it fails to indicate 27.065MHz even if you switch from ON position to CH-9 position when the switch is snapped very quickly.
6. Switching from CH-9 to ON position, it will never fail in indication of the frequency used last even if you snap it very quickly.

#### VOLUME/DARK:

The receiver volume is increased as this knob is turned clockwise. To pull it, the intensity of the meter and the frequency indicators will be moderately reduced. To push it back, the intensity will become normal again.

#### CLARIFIER (RIT)/NOISE BLANKER:

The Clarifier (RIT) is an electronic tuning circuit which shall allow you to shift the frequency on reception. In SSB operation, even small differences in frequencies between stations can cause poor reception. In effect, the clarifier shall electronically fine tune the station being received. In AM operation, this will act as a fine tune circuit.

It is the center of the clarifier when it is turned fully counter-clockwise with a click, which is clarifier function 0. The position just after a click on turning clockwise is for about -2KHz and the fully clockwise position is for +2KHz. Thus the clarifier function is about  $\pm 2$ KHz offset.

The N.B.(Noise Blanker) circuit will be on, when this knob is pulled, to cut off the incoming noise to the minimum level.

#### SQUELCH CONTROL:

The squelch control is used to eliminate the background noise when there are no signals present to overcome the noise. To adjust the squelch control, select a frequency where there is no signal. Turn the volume control up to normal listening levels. Rotate the squelch control clockwise until the background noise just disappears.

### FREQUENCY SELECTOR :

This is an electronic frequency selector. By first rotation it counts frequency slowly by the number of the figure selector already set and by second full position it counts it fast. By right rotation, frequency increases and by left it decreases.

### FREQUENCY FIGURE AND CW SWITCH:

This switch will ease to select the desired frequency and will function as CW switch as well.

There are indications of 100KHz, 10KHz, 1KHz, 100Hz and CW.

At each figure indication, the frequency of this figure can be moved and selected. The number of the 1MHz figure can be achieved by repeat running of the 100KHz figure.

For instance, 26.789MHz can be achieved in the following manner:

1. You set the figure selection to the 100KHz.
2. You continue to rotate the frequency selector until the frequency readout indicates 26.XXX.
3. Then you carefully handle the frequency selector to get 7 on the 100KHz figure.
4. Now you set the figure selector to the 10KHz figure.
5. And you get the number of 8 in the same manner as above.
6. Then you set to the 1KHz and get the number of 9.

Although the digital readout displays only 5 figures, 100Hz the 6th figure can also be controlled by setting the figure selector to the 100Hz and rotating the frequency selector. By rotating it, it counts 100Hz and this figure can be used for fine tuning both for TX and RX.

On the CW position, CW transmission can be operated without pushing the press-to-talk bar on the microphone. However release this position on each CW reception. That means you should switch back to any of the figure position on each CW reception. Otherwise CW reception will be impossible.

This position may be useful for a long continuous transmission on CW.

### MODE SWITCH:

You can select either AM, FM, LSB, USE and/or CW.

### S/RF METER:

In the receive position, it read the level of the incoming signals, and in the transmit position, it indicates the relative power output.

1. In the AM mode, the meter will read power at all times when the transmit button of the microphone is depressed. On SSB, however, it will only indicate RF output power when you modulate the signal.
2. In the SSB mode, no meter can follow the rapid voice peak power attained. Therefore, while the transmitter is developing much more power than on AM, the additional power will not be fully reflected on the meter.

### VXO ADJUSTMENT :

It is not necessary to adjust this potentiometer on the normal operation.

The purpose of this VXO adjustment is to adjust the TX/RX frequency to that indicated on the frequency readout LEDs. It will be possible to reduce or pull up the frequency by about 1KHz. This adjustment will of course be made with an accurate extra frequency counter attached.

### FREQUENCY DISPLAY :

These large and bright LEDs show the frequency you use. They indicate from 26.000 to 29.999MHz. The last figure is 1KHz.

The intensity can be reduced by pulling the volume knob.

### UP(RED)AND DOWN(GREEN) COUNT LAMP:

The red or green lamp will light on and off at a pace of one time by each counter step when upward or downward count is made by the frequency selector or UP or DN button on the microphone. The lamp will be kept illuminated when the automatic scanning is started and stays until the reverse counter is started by the frequency selector or UP/DN button on the microphone.

### CIRCUIT PROTECTION LAMP:

This lamp is located behind the frequency selector and will be lit when the built-in automatic protection circuit disables the transmitter due to excessive VSWR, shorted coaxial line or connector, or other antenna deficiencies. If this lamp is on, switch the transceiver off and check the antenna or its transmission line.

### MICROPHONE JACK :

The 8-pin Mic jack has the following internal connections:

- |                               |                                   |
|-------------------------------|-----------------------------------|
| 1. +12V for VOX unit etc.     | 6. Microphone input (Z600-10Kohm) |
| 2. Audio output (Z8-10Kohm)   | 7. AF out for selective call      |
| 3. Ground                     | 8. RIT                            |
| 4. Transmit/Receive switching |                                   |
| 5. Internal speaker           |                                   |

Always operate the transceiver with the microphone plug inserted in the microphone jack, or with the external connections illustrated on the next page.

### OTHER FEATURES AND FUNCTIONS

#### LOW-HIGH OUTPUT POWER SELECTION:

Pull both Volume and Clarifier (RIT) knobs.....Low power (about 10WPEP)  
One of the knobs is pulled or pushed .....High power (about 100WPEP)  
Push both Volume and Clarifier knobs .....High power (about 100WPEP)

#### AUTOMATIC SCANNING:

A particular feature of this transceiver is that you can scan either upward or downward. When you keep rotating the frequency selector, for instance, to the rightward for a few seconds, upward scanning will automatically start and will continue until a signal is present or you rotate the frequency selector to the leftward. Automatic scanning can also be started by pushing the UP or DN button on the microphone for a few seconds. It is considered that the automatic scanning is performed when the red or green lamp on the front panel starts to keep illuminated. The release of automatic scanning is made by reversely rotating the frequency selector or pushing UP/DN button on the microphone.

#### FREQUENCY MEMORY:

A useful feature of this transceiver is the frequency memory. The frequency you used last is memorized even after you switch off the transceiver and will work and be indicated again when you turn it on next by snapping the toggle power on-off switch to the left position.

1- Microphone with VOX.

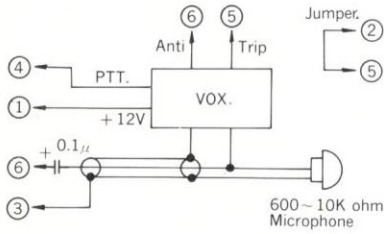

2. Headset or Telephoneset with PTT.

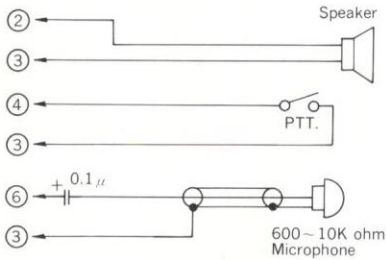

3. External Microphone

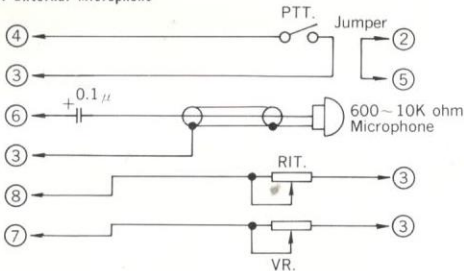

4. Headset or Telephoneset with VOX.

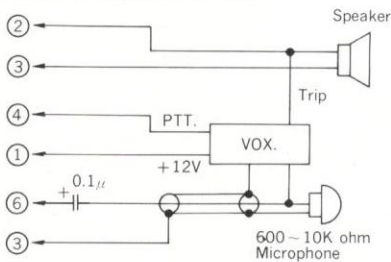

5. External Microphone Speaker with PTT.

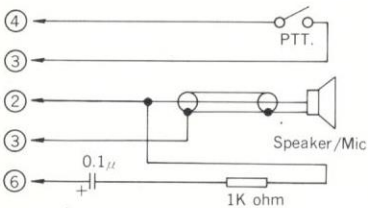

6. Telephone encoder Mic.

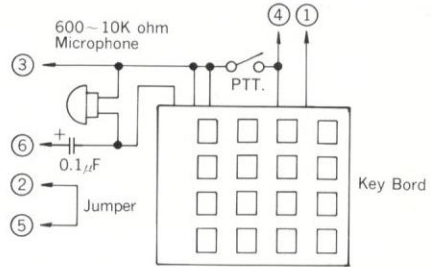

7. Internal connection

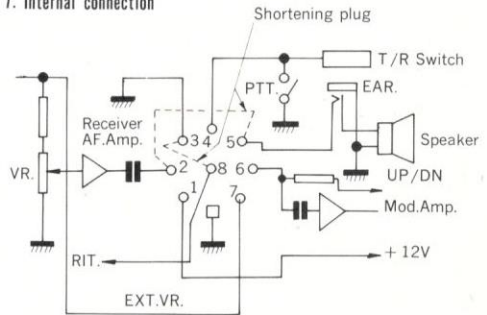

8. Internal connection with SP. selection switch

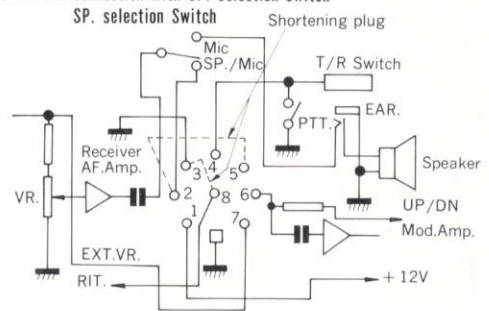

9. Connections number

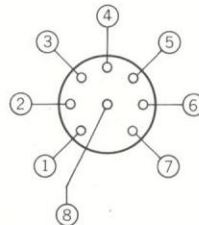

## REAR PANEL

### RF OUTPUT JACK:

Accepts standard PL-259 coaxial connector. Most PL-259 connector will mate satisfactorily if care is taken to seat them properly. If you have difficulty, try a different make of PL-259.

### EXTERNAL SPEAKER JACK:

You may add any 8-16 ohm external speaker. Connecting an external speaker will automatically disconnect the internal speaker.

### POWER CORD:

The red cord is positive(+) and the black is negative(-).

### S/RF-CALIB-SWR METER FUNCTION SWITCH & CALIBRATION:

In the top position of the 3-position slide switch found on the rear panel, the meter operates normally as S-meter and RF-output meter. In the center and the bottom position, the SWR (Standing Wave Ratio) can be measured. To measure the SWR of the antenna you use, select an open or little used frequency as close as possible to the center of the band, i. e. 28.000MHz.

1. Set the switch to C (Calibrate).
2. Press the PTT bar of the microphone and adjust the calibration potentiometer found on the rear panel so the meter needle is at the maximum position. And then release the PTT bar of the microphone.
3. Set the switch to SWR to the bottom position.
4. Press the PTT bar of the microphone again and read the SWR measurement on the bottom scale on the meter.
5. Then switch it to the S/RF position of the slide switch for normal operation. The SWR scale is calibrated at 1, 1.5, 2 and 3. If the meter pointer stops at 2 for instance, it can be said that the SWR is 2:1. It is recommended that the SWR does not exceed 1.5:1 or at maximum 2:1.

### CALIBRATION ADJUSTMENT:

This adjustment potentiometer is used to adjust the calibration so the meter needle on the front panel reads the maximum level in case the VSWR switch on the rear panel is switched to the center position.

### CW KEY JACK:

For operating a Morse Key device, connect a plug into the CW key jack provided on the rear panel of this transceiver, and set the mode switch to CW position. For tuning to an incoming CW signal, adjust the clarifier (RIT) control so that you can catch the tone frequency in the vicinity of 700Hz. Always press the PTT bar of the microphone or set the figure & CW switch to the CW position during CW transmission.

## SECTION V - OPERATIONS

### INITIAL PREPARATIONS:

- a. Connect the microphone to the microphone jack.
- b. Connect an antenna to the antenna jack. Make sure the coax line is of the correct impedance (50 ohms) and is neither short or open circuited.
- c. Make sure the power switch is in the OFF position. The RED cord should be connected to the positive side of the power source and the BLACK to the NEGATIVE side. In the event that these cords are improperly connected, the set will not function. No damage will be incurred since a protection circuit is provided for this purpose.
- d. Make sure if the supply voltage is adequate.
- e. Set the both volume and squelch control to the maximum counter-clockwise position.

### OPERATION:

- a. Snap the power switch either to the left or to the right, and the meter and the frequency display shall illuminate.
- b. Tune to the desired frequency by operating the frequency selector on the front panel, or by pushing the UP/DN button on the microphone.

### RECEPTION:

- a. Adjust the volume control to a comfortable listening level by turning it clockwise.
- b. With no signal present, turn the squelch control clockwise until the rushing noise just disappears. The set will now remain silent until an incoming signal is received, which opens the squelch.  
If the squelch is unstable due to the reception of weak or unstable stations, adjust the squelch control further until the proper threshold is obtained.
- c. The S-meter indicates the signal strength of the incoming stations.
- d. Set the clarifier (RIT) either on the front panel or on the microphone for best reception.

### TRANSMISSION:

- a. Push the PTT bar on the microphone and hold it until you finish your speech. On transmission, the meter needle shall stay on the red point and shall provide an indication of relative power output.
- b. Hold the microphone about 10-15cm from your mouth and speak in a normal tone of voice. Shouting does not increase your communication range.
- c. To receive again, just release the PTT bar.

**WARNING:** The microphone plug should always be completely inserted and 100% firmly fixed into the microphone jack with the microphone nut attached. Failure of doing so will result in improper or wrong functions with the transceiver.

Never operate the transceiver without an adequate antenna system or load. The antenna SWR should not exceed 2:1. Failure to follow this could result in damage to the output transistors.

## SECTION VI - CIRCUIT DESCRIPTIONS

### RECEIVER:

The RF input signal from the antenna is fed through a low pass filter (L22) to the band pass filter consisting of L1 & 2. While passing through L1 & 2, the signal is automatically tuned by D3 & 4 (varicap diode, both 1S2689) to one of the frequencies between 26.000–29.999MHz.

#### RF AMP:

The signal from B.P.F. (L1 & 2) is amplified by TR1 (2SC1856) and fed to the mixer circuit passing through a band pass filter (L3). While passing L3, the signal is automatically tuned by D5 (varicap diode, 1S2689) to one of the frequencies between 26.000–29.999MHz.

#### NOISE BLANKER CIRCUIT:

The impulse noise from the collector of TR1 (2SC1856) is fed to pin 2 of IC1 (HD-1211) via C15 and amplified by IC1. The amplified pulse which comes out from pin 5 of IC1 is connected to L4 through R18. When the impulse noise is fed to L4, the impedance is reduced and the impulse noise is consequently cut off.

#### MIXER CIRCUIT:

The signal from L3 is fed to gate 1 of TR2 (3SK40) of the mixer circuit, where the signal is mixed to produce IF signal of 10.7MHz with another signal delivered to gate 2 of TR2 from VCO (variable control oscillator) AMP, L27 of PLL circuit. The 10.7MHz IF signal is fed through L4 (10.7MHz tuning coil) to AMP circuit.

#### IF AMP CIRCUIT:

- (A) SSB and CW signals are fed to the emitter of TR3 (2SC1923) and amplified, and are delivered to the base of TR5 (2SC1923, IF AMP) via crystal filter XF1 (10F-2D).
- (B) AM and FM signals are fed to the emitter of TR4 (2SC1923) and amplified, and are delivered to the base of TR5 (2SC1923) via crystal filter XF2 (10F-8D).

The signal is impedance-converted by TR5 while coming out from the emitter of TR5, and is then fed through ceramic filter CF1 (SFE-10.7MS) to pin 5 & 6 of IC2 (SL-1612 for IF Amplifier and AGC).

- (A) The signals of AM, CW & SSB are amplified by IC2 and fed to pin 5 & 6 of IC3 (SL-1611 for IF AMP), where the signals are amplified and come out from pin 3.
- (B) The FM signal is amplified by IC2 and fed to pin 16 of IC5 (SL-6640 for FM, IF AMP).

The signals for all modes are delivered to SW-3D passing through the following routes.

**AM:**

The signal from pin 3 of IC3 is fed to the base of TR6 (2SC1923) for amplification and detected by D9 (1N60) after passing through L5. The detected audio frequency signals are delivered through D10 (1S2473) to SW-3D.

**CW, SSB:**

The signal from IC3 is fed to pin 7 of IC6 (SL-1640 for balance mixer) and mixed with another signal delivered to pin 3 of IC6 from TR9 (2SC1923 for 10.7 MHz. OSC) to produce AF signals which are fed to SW-3D.

**FM:**

The signal fed to pin 16 of IC5 is amplified, filtered and detected by IC 5, resulting in AF signal which is sent to SW-3D from pin 7 of IC5.

**AF AMP:**

The AF signals of AM, FM, CW & SSB from SW-3D are then fed to the base of TR8 (2SC1815), where the signals are amplified, and come out from the collector. The signals from TR8 are delivered via VR3 to pin 1 of IC4 (PC-5752 for AM Power AMP) and amplified. The AF signals are finally sent to the speaker through the mic. jack.

## TRANSMITTER

The speech signal from the microphone is fed to TR14 (2SC1815) for amplification and is then fed to pin 4 of IC8 (SL-1626 for AF AMP and ALC), where the signal is amplified, and comes out from pin 8. By means of ALC, the output power of this signal is always constant even though the signal over the fixed power comes into IC8. The signal from pin 8 of IC8 is fed through C150 & R117 to the base of TR13 (2SC1815) in the AF AMP circuit. Being amplified by TR13, the signal is sent through C148 to SW-3F and divided into 3 signals for AM, FM & SSB.

**FM:**

The AF signal which has been divided by SW-3F is fed via VR25, R286, etc. to D76 of VCO portion of PLL circuit to frequency-modulate the signal.

The AF signals of AM & SSB divided by SW-3F are sent to pin 7 of IC7 (SL-1640) in which the signals are balance-modulated by being mixed with other signals fed to pin 3 of IC7 from TR9 (2SC1923 for local oscillator) with the following frequencies.

AM, CW & FM.....10.7 MHz.  
USB .....10.6985 /  
LSB .....10.7015 /

**AM :**

The signal through VR13 goes to IC7, where the signal is balance-modulated and comes out from pin 5. The distortion of balance is adjusted by VR11.

**SSB :**

The signal through VR12 goes to pin 7 of IC7, where the signal is balance-modulated and comes out from pin 5. The distortion of balance is adjusted by VR9 & 10.

For AM, FM & CW, the 10.7MHz signal from IC7 is fed to the emitter of TR4 for amplification and then fed through XF-2 (10F-8D) to the base of TR5 (for IF AMP), where the signal is impedance-converted and comes out from the emitter. The signal from TR5 is sent via CF3 to pin 4 of IC9 (TA-7310 for balance mixer & AMP) in which the signal is mixed with another one (15.3-19.299MHz) delivered through L27 of PLL circuit.

When the signal from PLL circuit is unlocked, IC9 will not function as the unlocked signal grounds pin 1 of IC9, and the transmitter then ceases to work.

The signal mixed by IC9 is fed to TR16 (2SC2086) for amplification passing through L8 & 9 while being automatically tuned by D42 & 43 (varicap diode, both 1S2689) to one of the signals between 26.000–29.999MHz. The signal is then fed to TR19 (2SC1306) via L10 after automatically tuned by D44 (1S2689).

TR18 (2SA562 for low & high power change and ALC) is delivering the power voltage to pin 9 of IC9 (TA-7310) and is controlling the emitter current of TR16. TR18 is switched on and off by the key jack J4 (SL-296).

The signal amplified by TR19 (2SC1306) is fed to TR20 (2SC2098) for amplification. That signal passing through L.P.F. (L14-17) is impedance-converted by L18 and then fed to the base of TR21 (MRF-454), where the signal is power-amplified. The signal from TR21 is impedance-converted by L20 and fed through L.P.F. (L21 & 22) to the antenna.

L24 located between L21 & 22 and antenna is sensing SWR as well as output RF power (ALC). When SWR is over 3 : 1, the output RF power is stopped by means of D89 (SCR, FOR1B). The output RF power sensed by L24 is detected by D54 (1N60) and D55 (1S1555) and is delivered to the base of TR18 as the ALC voltage as mentioned above, and fed to the TX meter.

## PLL CIRCUIT AND FREQUENCY DISPLAY

### (1) PLL CIRCUIT

A basic oscillator of IC25 (TC-5082 for divider) oscillates the crystal X4 (10.24 MHz) and divides the frequency into 1/1024, resulting in the 10 KHz signal which is fed to pin 8 of IC26 (TC-5081P for phase comparator).

### LOCAL OSCILLATOR:

TR35 (2SC1923) oscillates the crystal X5 (11.3 MHz) as follows:

AM, FM & CW (TX) .....11.3 MHz.  
CW (RX) ..... 11.3007 MHz.  
USB ..... 11.3015 MHz.  
LSB .....11.2985 MHz.

D135 (varicap diode, 1S2339) is operated as VXO control and D78 (1S2339) as RIT control.

The above frequencies oscillated by TR35 are fed to the base of TR36 (2SC1923) for amplification and then fed through L29 to pin 3 of IC28 (SL-1640 for mixer) in which those signals are mixed with other ones (15.3–19.299 MHz) delivered to pin 7 of IC28 from TR32 (2SC1923 for VCO), resulting in 4.000–7.999 MHz signals. Those signals from pin 5 of IC28 are fed through the L. P. F. (L28) to the base of TR34 (2SC1923) for amplification. The amplified signals are then fed to pin 2 of IC27 (TC-9122 for programable divider) in which the signals are divided into 10 KHz. The 10 KHz signal from pin 17 of IC27 is then fed to pin 7 of IC26 (TC-5081P for phase comparator). Being phasecompared by IC26, the signal passes through the passive filter circuit (R281, C300, etc.) and controls D76 (1SV50) to properly activate TR32 (2SC1923 for VCO). The signal oscillated by TR32 is fed to pin 7 of IC28 (SL-1640) for mixture with one from TR35 as mentioned above. This signal is simultaneously fed through C313 to the base of TR33 (2SC1923, VCO AMP) for amplification. The signal from TR33 passes through L27 and is used as RX and TX local-oscillator signal. The signal via L27 is automatically tuned by D77 (varicap diode, 1SV50).

### DIGITAL/ANALOGOUS CONVERTER CIRCUIT AND

#### LOCAL OSCILLATOR CONTROL:

The D/A converter circuit is consisted of IC22, 23 & 24 (all MC-14069B, Hex Inverter) and IC29 (NJN-4559D). The analogous voltage is produced through the D/A converter circuit by the BCD (Binary Cord Decimal) output power for 2 figures of 1 KHz and 100 Hz. The analogous voltage is fed to the varicap diode, D79 (SVC-201Y) & D80 (SVC-321B) to vary the oscillating frequency of the crystal X5. The change of VCO output power for 1 KHz & 100 Hz is, therefore, gained by alternating the local oscillator frequency of the crystal X5.

#### AUTOMATIC TUNING CIRCUIT:

The 1 MHz and 100 KHz signals are D/A-converted through IC29 by IC22 & 23 (both MC-14069B). The converted analogous voltage is fed to the varicap diodes in the automatic tuning circuit of RX and TX.

## (2) FREQUENCY DISPLAY CIRCUIT

The UP/DOWN counter is consisted of IC14, 15, 16, 17 & 18 (all MC-14510B). IC14 operates the frequency for 1MHz, IC15 for 100KHz, IC16 for 10KHz, IC17 for 1KHz & IC18 for 100Hz. The output powers of these ICs are delivered to the following 3 sections.

- (A) One of the output power is fed to IC10, 11, 12 & 13 (all TC-5022 for LED 7 segment drive) in order to illuminate LED frequency display of 26,000 – 29,999 MHz. The display counter has 5 figures and the first 10MHz figure is always displayed as 2. Each LED common is connected to the collector of TR27 (2SD880) and the LED functions only when the set is switched on. Further, LED intensity dimmer is connected to the base of TR27 and is adjusted by VR31.
- (B) The other output power is fed to IC20 (MC-14001B, Quad 2-Input "NOR" gate), IC21 (MC-14081B, Quad 2 Input "AND" gate) & IC22 (MC-14069B, Hex Inverter) by which UP/DOWN counter is previously set to count the frequency between 6.000.0–9.999.9 MHz. When UP counter is operated, the frequency turns from 26.000 to 29.999 MHz. and in case of DOWN counter, the frequency turns from 29.999 to 26.000 MHz. by means of the above ICs.
- (C) Furthermore, the output power is fed to IC27 (TC-9122P, programable divider) to operate PLL circuit as already mentioned.

## (3) UP/DOWN SCAN CIRCUIT

The UP/DOWN SCAN circuit is consisted of IC30 (MC-14011B, Quad 2-Input "NAND" gate), TR44 (2SC1015 for UP switch), TR43 (2SC1815 for DOWN switch) & IC32 (MC-14011, Quad 2 Input "NAND" gate) which are operating UP/DOWN counter (IC14–18). The UP/DOWN counter functions only when the set is switched on by means of TR45 which activates TR43 & TR44. The UP-counter operation is made by the activation of TR44 and DOWN by TR43.

The signal for the SCAN STOP circuit is taken from the detector circuit in RX circuit and is fed to the gate circuit of IC31 (TC-14011BP, Quad 2-Input "NAND" gate) of which output power ceases the clock oscillation of IC32, and the SCANNING stops consequently.

## (4) UP (RED) AND DOWN (GREEN) LED INDICATOR

When the frequency selector knob is rotated to the up-count direction, the signal from IC32 is fed to TR38 (2SC1646B) which lights up LED lamp in red colour. In case of the down-count rotation, the signal from IC32 is fed to TR39 (2SC1646B) which lights up LED lamp in green colour. When SCANNING is operated, the signal from IC30 is fed to TR38 or TR39 by which LED lamp in red or green is continuously kept illuminating.

## DC STABILIZER

When the source of electricity is connected to the TS-788DX transceiver, TR30 (2SD-880V) functions even without snapping the power on-off switch and it produces the source of stabilized-voltage electric power of 7V which is supplied to the counter circuit. TR25 (2SB435 for TX) and TR26 (2SC496 for RX) are used for switching the power sources of TX and RX. TR26 is supplying the stabilized-voltage of 7V to RX circuit. The source of electric power from TR25 is converted by TR24 (2SD880) into 8.5V of stabilized-voltage which is supplied to TX circuit. TR23 (2SC496) is used for discharging the remaining voltage of TX in case TX is switched to RX. When the power switch is on, TR22 (2SC496) produces the source of stabilized-voltage electric power of 7V which is supplied to the common circuit for both TX and RX of IF circuit.

## SECTION VI - MAINTENANCE AND ALIGNMENTS

This transceiver has been carefully aligned and tested at the factory prior to shipment. The reliability of the solid devices used in TS-788DX should provide years of trouble-free services if the equipment is not abused and the proper routine maintenance is carried out. This section describes the adjusting sequence and procedures of TS-788DX. Please do not attempt to adjust the transceiver without using the proper measuring instruments listed in this manual.

### RECEIVER ADJUSTMNT

#### I. Measuring Instruments:

- a) DC Power Supply 11-16V
- b) Signal Generator
- c) Voltmeter

#### 2. Sensitivity Adjustment:

- (1) Mode.....AM, Freq.....28.000 MHz Frequency Figure.....100 KHz
  - i. Connect the signal generator to the antenna receptacle and set the output of the SG to 90 dB. Adjust L5 for maximum reading on the voltmeter so that AGC will become best.
  - ii. Set the output of the SG to -10dB. Adjust L1, 2, 3 & 4 for maximum reading on the voltmeter.
  - iii. Set the output of the SG to -10dB. And adjust the RIT potentiometer for maximum reading on the voltmeter so that the transceiver tunes to 28,000 MHz correctly. And then adjust L1, 2, 3 & 4 again for maximum reading on the voltmeter.
  - iv. Set the output of the SG to 60dB. and place the VSWR switch on the rear panel in S/R position. Set the indicator of RX meter to 9 by adjusting VR28. This is for RX meter adjustment.
  - v. Set the output of the SG to -8dB and switch off the squelch potentiometer. Check and confirm on the voltmeter if the difference between "ON" and "OFF" of the squelch switch is over 15dB. This is ANL adjustment.
- (2) Mode.....FM, Freq.,.....28,000 (or 27,065 MHz)  
For adjustment FM, you should not rotate both RIT potentiometer and Channel Selector. Connect the SG to the antenna receptacle and set the output of the SG to 20dB. Adjust L6 for maximum reading on the voltmeter.
- (3) Mode.....SSB and CW  
No special adjustments are necessary for receiver sensitivity.

#### 3. Adjustment of Frequency Range (26,000-29,999 MHz):

If L1, 2, 3, 4 & 5 are adjusted properly as described above, the adjustment of frequency range is unnecessary. In case these adjustments are not well enough performed, rotate L1 clockwise so that the good S/N of high channel side (29,999MHz) can be obtained. Good S/N of low channel side (26,000 MHz) can be obtained by rotating L1 counter-clockwise.

#### 4. Adjustment of Scanning Stop Sensitivity:

- i. Set the output of the SG to 20dB in 28,000 MHz.
- ii. Adjust VR1 so that scanning stops with 25-35 dB.

- iii. Rotate VR30 so that its resistance becomes maximum.  
Move the frequency of the transceiver around 20-30 KHz from 28,000 MHz up or down by turning the frequency selector knob, and let the transceiver start scanning down or up. It will stop at the point of catching RX signal. Even if it stopped, for example, during up scanning, it will never start scanning again if you rotate the frequency selector knob upward again. This is because VR30 has been so adjusted. Now you keep rotating the frequency selector knob upward and simultaneously return to rotate VR30 to the point carefully where it just starts scanning.

## TRANSMITTER ADJUSTMENT

### I. Measuring Instruments:

- a) Voltmeter
- b) Signal Generator
- c) Power Supply 11-16V DC
- d) Watt Meter
- e) Frequency Counter
- f) Oscilloscope
- g) Two Tone Generator (Audio Generator)
- h) FM Linear Detector
- i) Tester

### 2. Adjustments of Output Power and Modulation Capacity:

- (1) Mode.....AM, TX Freq.....28,000 MHz
  - i. Connect the frequency counter and watt meter to the antenna receptacle of transceiver. Rotate the core of L8, 9, 10, 12 & 14 so that the watt meter will give the maximum indications. Before the above adjustments, check up the frequency counter and confirm on the frequency counter whether the transceiver is sending the correct frequency.
  - ii. Adjust VR7 until the watt meter reading indicates 20-30W as the high power. Connect the output of the audio generator to the Mic. input and feed 1 KHz signal to the transceiver. Adjust VR11 & 13 to get the good modulation sensitivity and modulation wave on the oscilloscope.
  - iii. If there is the difference of TX output power between high channel and low channel, adjust it as follows:
    1. Set the frequency to 29.999 MHz and adjust L9, 10 & 12 and VR15 for the maximum reading on the watt meter.
    2. Set the frequency to 26.000 MHz and adjust L8 for the maximum reading on the watt meter.In this way you can keep the balance between the high channel and low channel within about  $\pm 2.5W$ . In case that the power of 26.000 MHz is higher than one of 29.999 MHz., adjust it by rotating L10 clockwise.
- iv. ALC :  
Adjust VR20 and make the good balance of frequency range (26.000-29.999 MHz) checking on the watt meter.

(2) Mode.....FM or CW

If AM power is adjusted properly, no adjustment is required as to FM or CW power. If the output is weak, adjust VR7 checking on the watt meter. When you move VR7, confirm again whether AM power is still correct.

ALC:

Adjust VR21 and make the good balance of frequency range (26.000-29.999 MHz) checking on the watt meter.

Adjust FM Modulation Capacity by VR25 checking on the FM linear detector and control the deviation around 2KHz in 26.000 MHz and around 0.5-2 KHz in 29.999 MHz. In this case Modulation Input power is 3mV.

(3) Mode.....USB or LSB

If AM or FM power is adjusted properly, no adjustment is required as to SSB power.

Adjustment of SSB Wave Figure:

Connect the output of the signal generator to mic. input. Adjust mic. sensitivity by VR12 and Carrier Balance of Balance Modulation Circuit by VR9 & 10. Connect the two tone generator to mic. input. Adjust the bias of SSB drive position by VR16 so that the distortion of SSB wave will be corrected.

Adjust the low power by VR8 checking on the watt meter.

(4) Adjustment of CW Keying Monitor

It is the adjustment of keying monitor volume when sending CW signal. Set VR5 at the center position where the voltmeter reading will indicate 1V.

(5) Standardized TX Output Power

	High Power	Low Power
AM	20 - 30 W	over 4 - 10 W
FM, CW	60 - 80 W	over 20 - 40 W
USB	50 - 70 W	10 - 30 W
LSB	50 - 70 W	10 - 30 W

\* Electric current: within 12A. maximum

### 3. Meter Adjustment:

(1) RF Meter

Mode.....FM or CW

High power: Set the VSWR switch of rear panel to S/R position. Adjust VR19 to 20dB on the S/RF meter.

(2) SWR Meter

Mode.....FM or CW

Set the SWR meter of rear panel to the middle position, C (Calibration). Set the pointer of meter to the full scale by adjusting volume knob of transceiver. Next, change the VSWR switch to the bottom position, SWR. Adjust TC4 to the minimum scale. Keep the SWR meter within 1.5 : 1 in 50 Ohm Load.

4. Protection Circuit Adjustment:

Mode.....AM

Voltage of Power Supply.....11V

Antenna.....Open or Short circuit

This circuit operates mainly to protect the final transistor TR21 by ceasing the work of TR16 when SWR exceeds 3 : 1.

After switching on the power, adjust VR29 and observe the lighting of protection circuit lamp. Move VR29 clockwise seeing from the front panel side and set VR29 at the position where a red lamp just lights up.

ADJUSTMENT OF LOCAL OSCILLATOR AND SUB-PRINTED BOARD

1. Measuring Instruments:

- a) Frequency Counter
- b) Oscilloscope
- c) DC Power Supply 14V
- d) Tester

2. Local Oscillator Adjustment:

(1) Main Printed Board

Crystal, X1 for LSB: Adjust the frequency of 10.7015 MHz. by TC1.

Crystal, X2 for USB: Adjust the frequency of 10.6985 MHz. by TC2.

Crystal, X3 for AM & FM: Adjust the frequency of 10.7000 MHz. by TC3.

The hint of the above measurement:

Couple a condenser of the smallest possible capacitance on the probe and apply to the emitter of TR9 and read the following frequencies on the frequency counter.

	AM, FM	CW	USB	LSB
RX	—	10.6985 (X2)	10.6985 (X2)	10.7015 (X1)
TX	10.7000 (X3)	10.7000 (X3)	10.6985 (X2)	10.7015 (X1)

(2) Sub-Printed Board

Crystal, X4 for PLL Base Oscillator Frequency:  
Adjust the frequency of 10.240 MHz by TC9.

The hint of the measurement:

Apply the probe coupling the condenser of the smallest possible capacitance to Pin 2 of IC25 and read the frequency of 10.240 MHz on the frequency counter.

Crystal, X5 for PLL Local Oscillator (Adjustment of PLL 11.3 MHz)

Mode.....AM or FM

Freq..... 28.000 MHz

- i. Set the Trimmer Capacitor, TC5, 6, 7 & 8 to the center position.
- ii. Switch off RIT Volume and produce the frequency of 11.3 MHz by rotating L30.

The hint of this measurement:

Connect the frequency counter to the secondary position of L29 and read the frequency of 11.3 MHz.

**3. PLL LOCK:**

- (1) PLL Lock is achieved after X5 (11.3 MHz), X4 (10.240 MHz) and VCO (X1, 2 & 3) were properly adjusted. Set the channel to 29.999 MHz and rotate L26 clockwise checking the frequency counter so that you will find the place that the frequency is locked. From that position rotate L26 about 60 degrees to the clockwise position so that you can read 19.3 MHz on the secondary position of L27. Change the channel to 26.000 MHz and confirm the frequency of 15.3 MHz. All channels are now being locked consequently.

(Note) When PLL Lock is performed, the voltage should be between 0.5V (26.000 MHz) and 4.7V (29.999 MHz) on Pin 3 of IC25.

Please be noted that the Local Oscillator is actually adjusted within  $\pm 500 - 1,500$  Hz for both 15.3 MHz in low channel (26.000 MHz) and 19.3 MHz in high channel (29.999 MHz). That is why the influence of temperature or long-term use are previously considered. Such the adjustment is performed by TC5, 6, 7 & 8 as follows:

Mode	Trimmer Capacitor	26.000 MHz.		29.999 MHz.	
		15.3 MHz	0	19.3 MHz.	0
AM & FM	TC5	15.3 MHz	0	19.3 MHz.	0
CW	TC6	15.3007 MHz	+ 700 Hz.	19.3007 MHz	+ 700 Hz.
USB	TC7	15.3015 MHz	+ 1,500 Hz.	19.3015 MHz.	+ 1,500 Hz.
LSB	TC8	15.2985 MHz	- 1,500 Hz.	19.2985 MHz.	- 1,500 Hz.

(2) Channel Selector :

Adjust the voltage of low channel (26.000 MHz) and high channel (29.999 MHz) by moving the following pots.

\* Frequency.....26.000 MHz (low channel)

Set the frequency figure to 100 KHz and adjust VR23 so that the tester indicates 1.5V. Next, set the frequency figure to 100 Hz and adjust VR24 to 1.8V on the tester.

\* Frequency.....29.999 MHz (high channel)

Set the frequency figure to 100 Hz and adjust VR26 to 4V on the tester. Next, set the frequency figure to 100 KHz and adjust VR27 to 4.5V on the tester.

The hint of the above measurements :

Apply the tester to Pin 1 of IC1 for adjustment of VR24 & 26 and to Pin 7 of IC1 for adjustment of VR23 & 27.

4. RIT Adjustment :

- i. First, switch off the RIT Volume and check the frequency on the frequency counter.
- ii. Switch on the RIT Volume and observe if the same frequency as of the above i. is found in some place within the variable range of the RIT.
- iii. Next, adjust VR4 so that the frequency as above stays on the center of the variable range of the RIT. The difference under 100-200 Hz will be acceptable.

5. The Correction of TX Frequency :

Mode.....AM or FM

Rit Volume.....OFF.

Apply the probe of the frequency counter to the secondary position of L27 and adjust VR14 so that TX and RX frequency stays same.

(Remark: )

After finishing all adjustments, it is absolutely necessary to connect the speaker connectors to the proper poles, the red wire to the positive pole (+) and the black wire to the negative pole (-). Otherwise it may self-oscillate on FM mode.



# COMPLETE PARTS LAYOUT

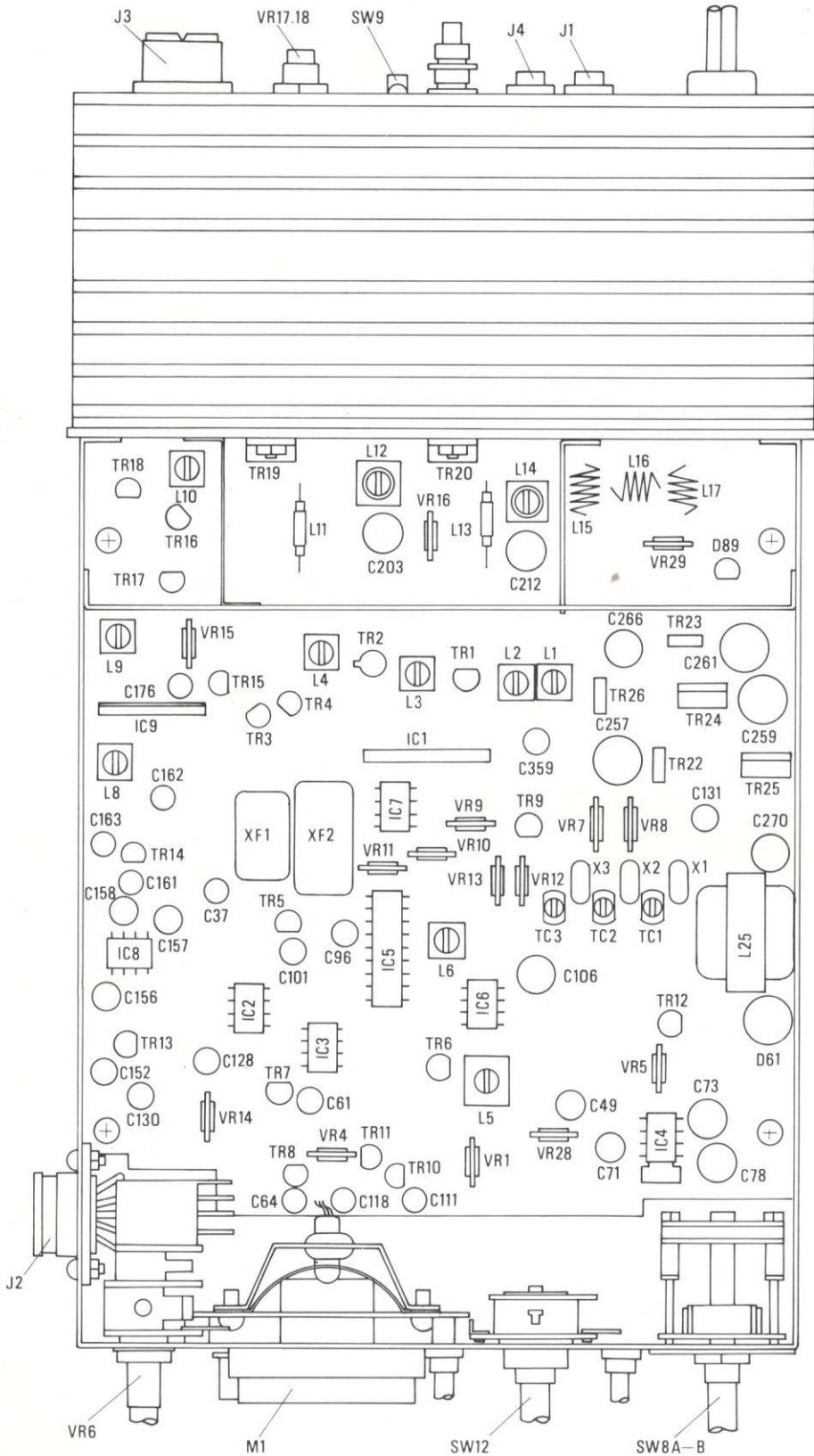







# PRINTED CIRCUIT BOARD PARTS LAYOUT

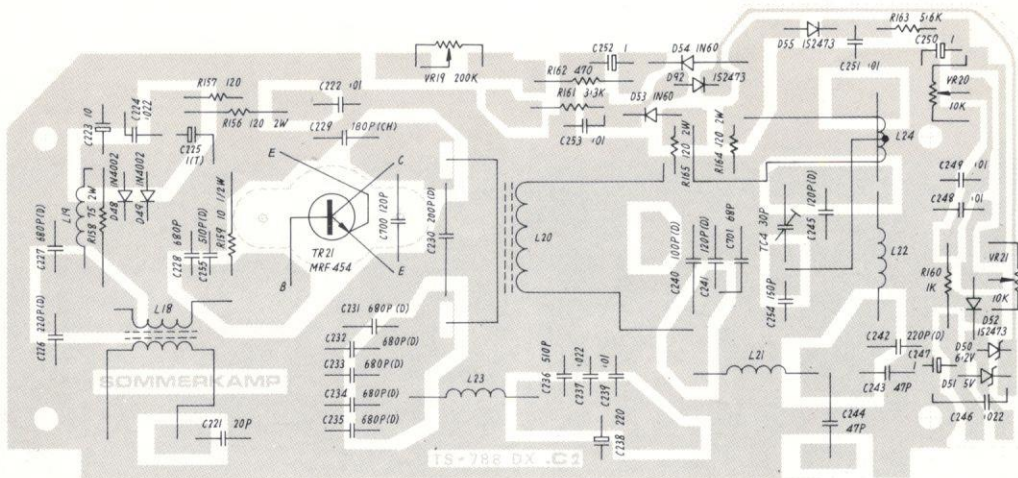

# WIRING LAYOUT

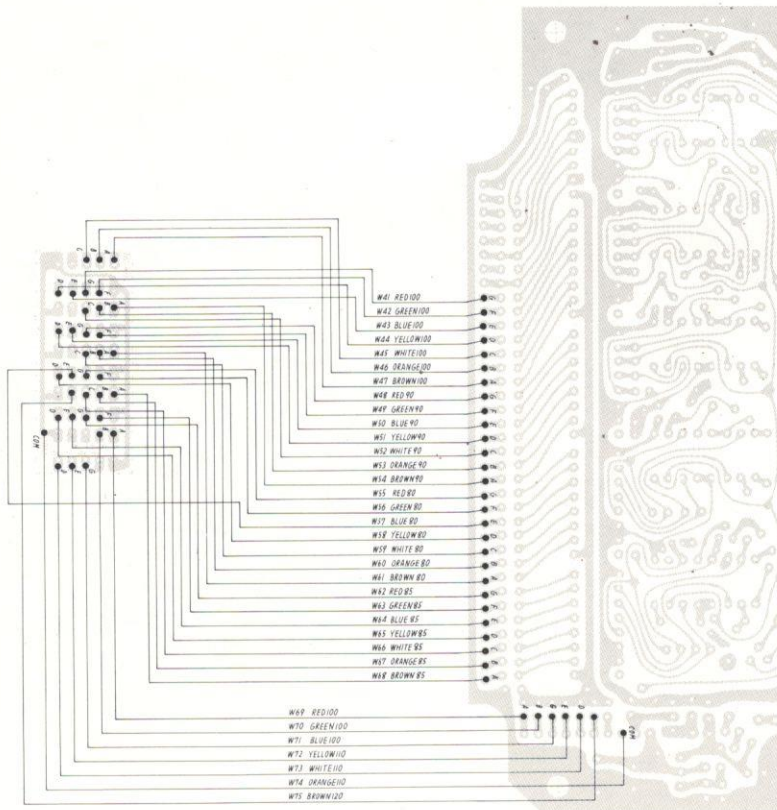

# CIRCUIT DIAGRAM

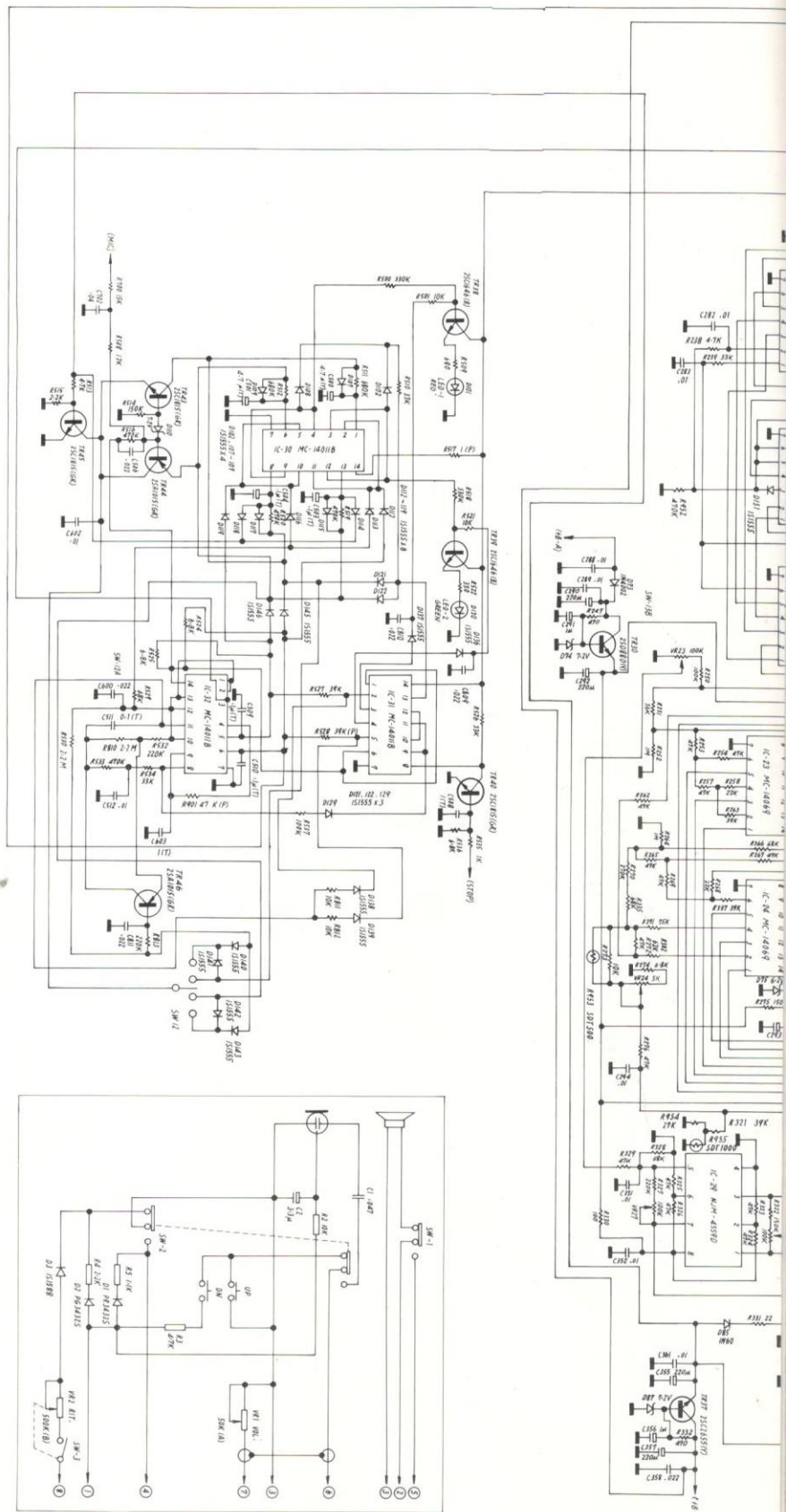

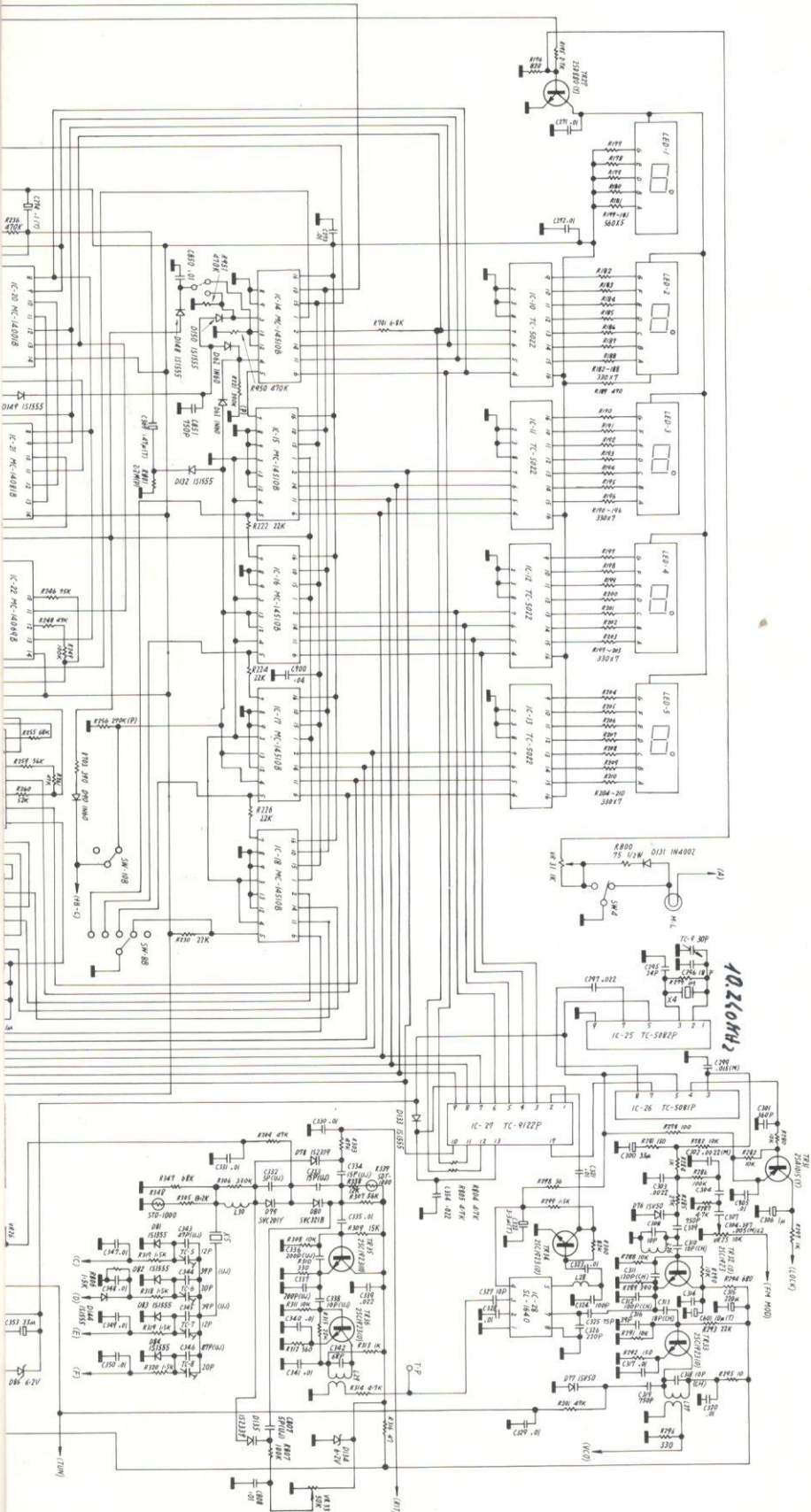

1403201



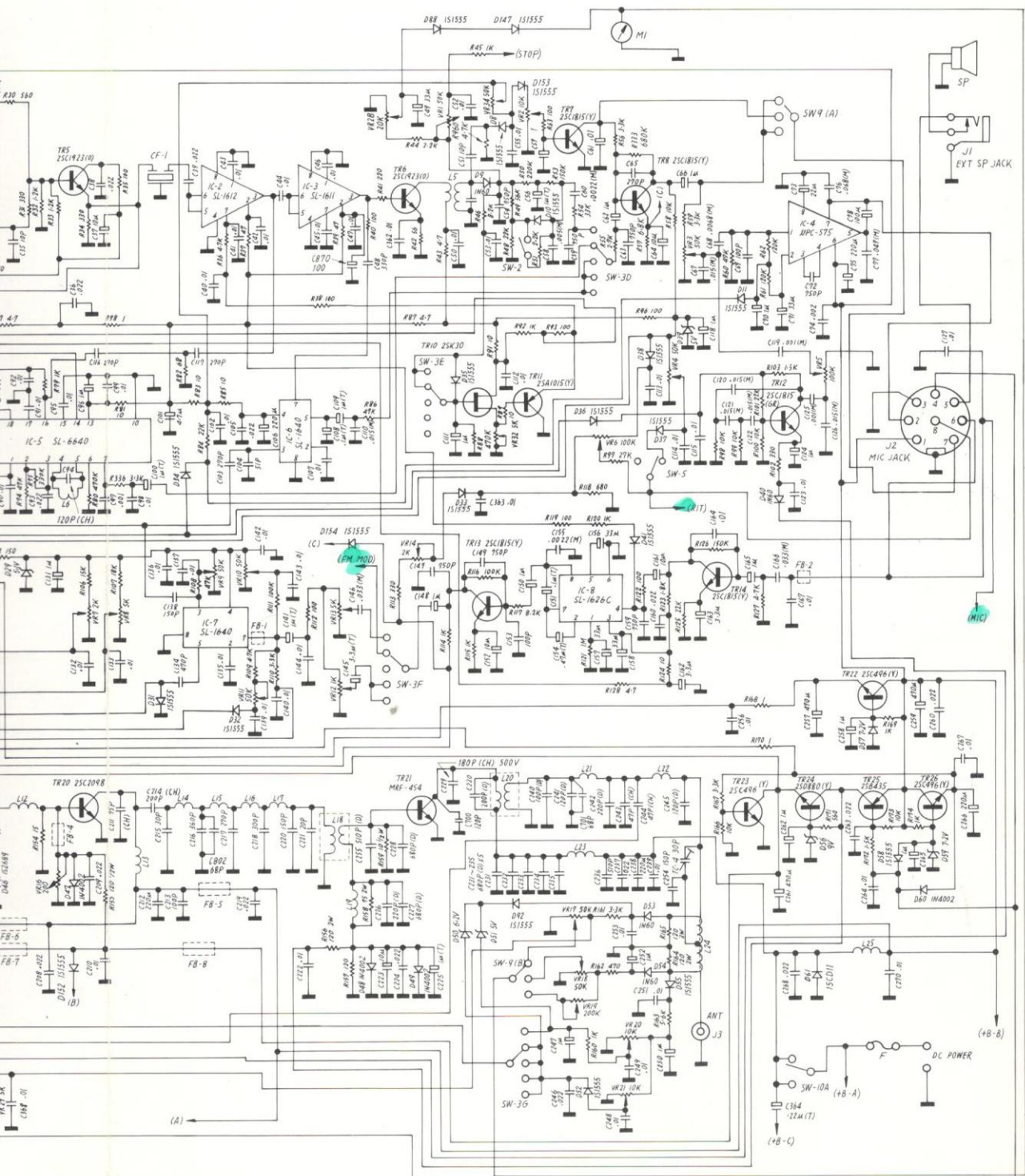

Subject to change without notice.

# WIRING LAYOUT

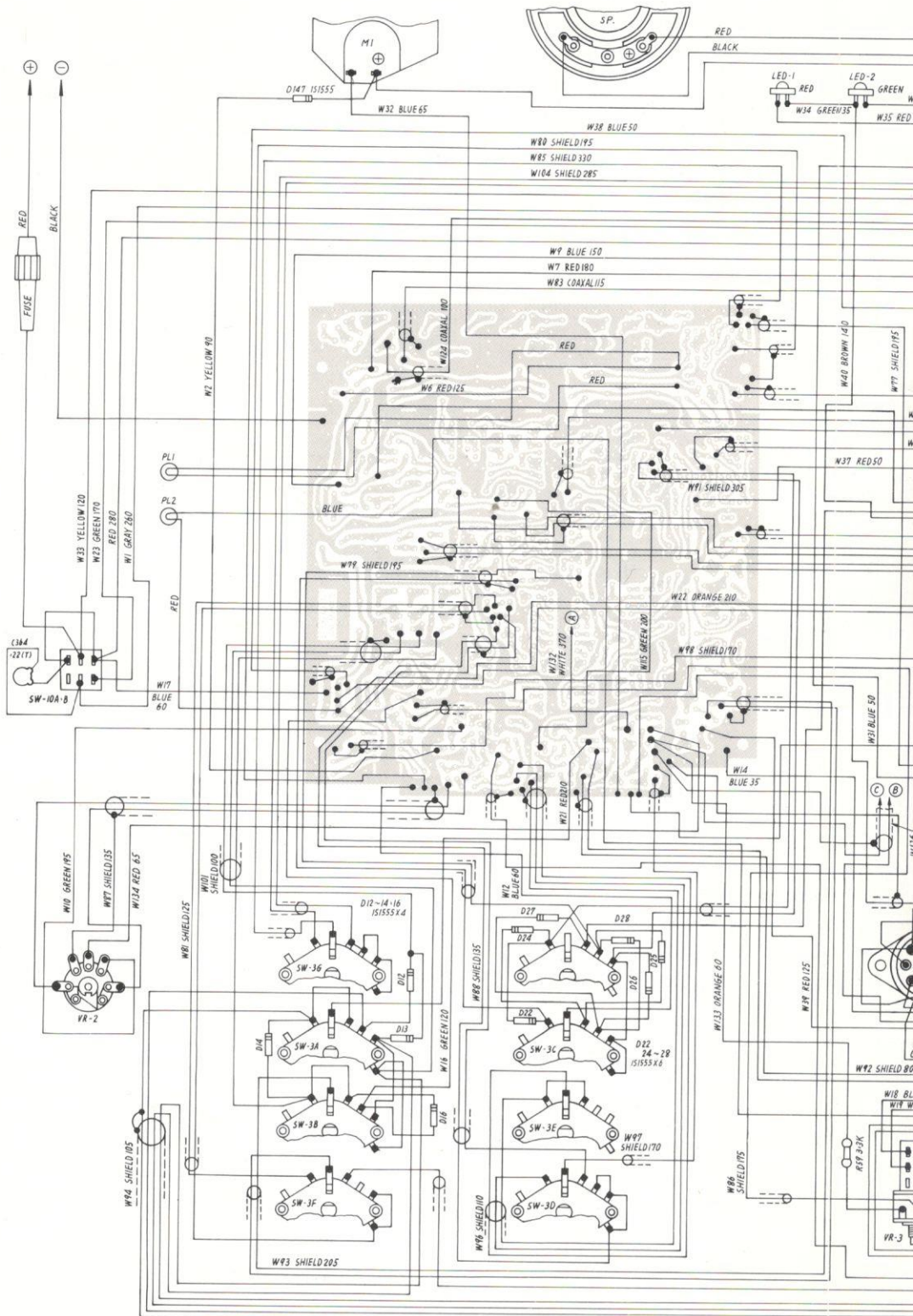



# VOLTAGE CHART

NOTE: (T) TRANS. (R) RCIV.

TESTER  
DC: — 20K $\Omega$ /V  
AC: — 30MHz Scope

DC VOLT (Voltage in bracket Vpp)				DC VOLT (Voltage in bracket Vpp)			
TR:NO	TR	BASE	EMITTER	COLLECTOR	TR:NO	TR	COLLECTOR
1	2SC1856	2.5	1.8	5.4	26	2SC496(Y)	13.8
3	2SC1923(O)	1.8	1	3.3	27	2SD880(Y)	0.2
4	2SC1923(O)	1.9	0.8	4.5	30	2SD880(Y)	13
5	2SC1923(O)	3.2	2.4	5.6	31	2SA1015(Y)	5.6
6	2SC1923(O)	1.5	0.8	6	32	2SC1923(O)	4.4
7	2SC1815(Y)	—	—	7	33	2SC1923(O)	6.5
8	2SC1815(Y)	0.7	0.4	2.3	34	2SC1923(O)	2.4
9	2SC1923(O)	1.8	1.2 (0.3)	6.2	35	2SC1923(O)	6.3
11	2SA1015(Y)	1.5	2.2	—	36	2SC1923(O)	4.8
12	2SC1815(6R)	1.5	1	2.7	37	2SC2060(Q)	13.8
13	2SC1813(Y)	2.4	2.2	4.2	38	2SC1646(B)	9
14	2SC1815(Y)	1.9	1.6	5.7	39	2SC1646(B)	7
15	2SC1815(6R)	—	—	2.5	40	2SC1815(6R)	6
16	2SC2086	0.8	0.6	13.5	43	2SC1815(6R)	0.2
17	2SA562(O)	4.8	13.8	13.8	44	2SA1015(6R)	6
18	2SA562(O)	0.3	0.5	—	45	2SC1815(6R)	0.2
19	2SC1306	0.4	—	13.5	46	2SA1015(6R)	0.2
20	2SC2098	0.4	—	13.5			1.3
21	MRF454	0.5	—	13.8			
22	2SC496(Y)	7.2	6.5	13.8			
23	2SC496(Y)	0.4	—	8.5			
24	2SD880(Y)	9	8.5	13			
25	2SB435	12	13.8	13			

DC VOLT (Voltage in bracket Vpp)				DC VOLT (Voltage in bracket Vpp)			
TR:NO	FET	GATE (1)	GATE (2)	DRAIN	SOURCE	TR:NO	FET
2	3SK40	—	—	5.9	0.5	2	3SK40
10	2SK30	—	—	6	1.5	10	2SK30

DC VOLT	
ON	OFF
VXO	
RIT	

		PIN NO / DC VOLT (Voltage in bracket Vpp)																											
IC NO	IC	1	2	3	4	5	6	7	8	9	10	11	12	13	14	15	16	17	18	19	20	21	22	23	24	25	26	27	28
1	HD-1211	—	0.8	2.2	6	5.9	—	—	—	—	—	—	—	—	—	—	—	—	—	—	—	—	—	—	—	—	—	—	—
2	SL-1612	—	6	2.3	—	0.9	—	2	—	—	—	—	—	—	—	—	—	—	—	—	—	—	—	—	—	—	—	—	—
3	SL-1611	—	5.5	1.7	—	—	—	—	—	—	—	—	—	—	—	—	—	—	—	—	—	—	—	—	—	—	—	—	—
4	MPC-575	1.6	13.8	13	7.2	6.2	13.8	0.3	1.9	—	—	—	—	—	—	—	—	—	—	—	—	—	—	—	—	—	—	—	—
5	SL-6640	5	5.2	0.8	4	4	5.8	1.8	—	—	—	—	—	—	—	—	—	—	—	—	—	—	—	—	—	—	—	—	—
6	SL-1640	—	2.8	2.7	5.9	5.2	—	2.8	—	—	—	—	—	—	—	—	—	—	—	—	—	—	—	—	—	—	—	—	—
7	SL-1640	—	3	3	6.2	5.6	—	2.8	—	—	—	—	—	—	—	—	—	—	—	—	—	—	—	—	—	—	—	—	—
8	SL-1626C	0.3	2.9	6	1.2	1	—	1.4	1.4	—	—	—	—	—	—	—	—	—	—	—	—	—	—	—	—	—	—	—	—
9	TA-7310	2.6	—	—	2.6	—	4.6	2.2	4.6	13.8	—	—	—	—	—	—	—	—	—	—	—	—	—	—	—	—	—	—	—
25	TC-5082P	—	2	2.4	—	5.5	—	1.8	—	—	—	—	—	—	—	—	—	—	—	—	—	—	—	—	—	—	—	—	—
26	TC-50891P	—	—	0.5	—	—	5.5	—	2.2	—	—	—	—	—	—	—	—	—	—	—	—	—	—	—	—	—	—	—	—
28	SL-1640	—	2.3	2.5	5	4.5	—	2.3	—	—	—	—	—	—	—	—	—	—	—	—	—	—	—	—	—	—	—	—	—
29	NJM-4559D	1.5	3	0.9	—	0.9	3	2.6	6.6	—	—	—	—	—	—	—	—	—	—	—	—	—	—	—	—	—	—	—	—

## SECTION IX - PARTS LIST

DESIGNATION	PARTS NAME	PARTS NO.
IC. 1	Integrated circuit	HD-1211
IC. 2	Integrated circuit	SL-1612
IC. 3	Integrated circuit	SL-1611
IC. 4	Integrated circuit	$\mu$ PC-575C2
IC. 5	Integrated circuit	SL-6640
IC. 6, 7, 28	Integrated circuit	SL-1640
IC. 8	Integrated circuit	SL-1626C
IC. 9	Integrated circuit	TA-7310
IC. 10, 11, 12, 13	Integrated circuit	TC-5022
IC. 14, 15, 16, 17, 18	Integrated circuit	MC-14510B
IC. 20	Integrated circuit	MC-14001B
IC. 21	Integrated circuit	MC-14081B
IC. 22, 23, 24	Integrated circuit	MC-14069B
IC. 25	Integrated circuit	TC-5082P
IC. 26	Integrated circuit	TC-5081P
IC. 27	Integrated circuit	TC-9122P
IC. 29	Integrated circuit	NJM-4559D
IC. 30, 31, 32	Integrated circuit	TC-4011BP
TR1	Transistor	2SC1856
TR3,4,5,6,9,32,33,34,35,36	Transistor	2SC1923 (O)
TR7, 8, 13, 14	Transistor	2SC1815 (Y)
TR11, 31	Transistor	2SA1015 (Y)
TR12, 15, 40, 43, 45	Transistor	2SC1815 (GR)
TR16	Transistor	2SC2086
TR17, 18	Transistor	2SA562 (O)
TR19	Transistor	2SC1306
TR20	Transistor	2SC2098
TR21	Transistor	MRF-454
TR22, 23, 26	Transistor	2SC496 (Y)
TR24, 27, 30	Transistor	2SD880 (Y)
TR25	Transistor	2SB435
TR37	Transistor	2SC2655 (Y)
TR38, 39	Transistor	2SC1646 (B)
TR44, 46	Transistor	2SA1015 (GR)
TR2	FET	3SK40
TR10	FET	2SK30 (A)
LED1~5	LED	FND-357
D1, 2, 6~8, 10~20, 22, 24~28, 31~33, 34, 35~38 41, 52, 55, 58, 62, 81~84, 88, 92, 102, 107 108, 109, 112~119, 121~122, 129, 130, 132, 133 136, 137, 138~144, 146, 147, 150, 151	Silicon Diode	1S1555
	Silicon Diode	1S1555
D61	Silicon Diode	15CD11

DESIGNATION	PARTS NAME	PARTS NO.
D3, 4, 5, 42, 43, 44, 46	Varicap Diode	1S2689
D80	Varicap Diode	SVC-321B
D79	Varicap Diode	SVC-201Y
D9, 40, 53, 54, 63, 64, 65, 85, 90	Germanium Diode	1N60
D45, 47, 48, 49, 60, 73, 131	Silicon Diode	1N4002
D78, 135	Varicap Diode	1S2339
D76, 77	Varicap Diode	1SV50
D89	SCR	FOR1B
D39, 51, 29	Zener Diode	WZ-050
D21, 50, 75, 86, 134	Zener Diode	WZ-062
D57, 59, 74, 87, 110	Zener Diode	WZ-072
D56	Zener Diode	WZ-090
D101	LED	TLR-102KB
D120	LED	TLG-102KB
XF-1	X'tal Filter	10F-2D
XF-2	X'tal Filter	10F-8D
CF-1 ~ 3	Ceramic Filter	SFE-10-7MS
M-1	Meter	OS-601
SP	Speaker	F70C02
J1	Ext. SP. Jack	SJ-296
J4	Key Jack	SJ-296
J2	Mic. Jack	8P
J3	Ant. Jack	MRM/INCH
SW-3A ~ 36	Rotary Switch	S32BP (24) 1-2-5W
SW-8A ~ 8B	Rotary Switch	ESR-E125K25A
SW9	Slide Switch	SS (H) -23-05
SW-10A ~ 10B	Toggle Switch	8S-2021
SW-12	Frequency Selector Switch	GM-71E5M1A41
TC1 ~ 3, 5, 7	Trimmer 12PF	CV05-C120
TC6, 8	Trimmer 20PF	CV05-D2001
TC-4, 9	Trimmer 30PF	CV05-E300
FB1 ~ 4	Ferrite Beads	T314, OP-3-5-3-IH
FB5 ~ 8	Ferrite Beads	T314, OP-3-5-6-IH
VR2	Variable Resistor (SQU) 10K ohm	V12M4-IS
VR3	Variable Resistor (VOL) 50K ohm	VM13E-VER22
VR6	Variable Resistor (RIT) 100K ohm	GM86E507A-UER22-100KB
VR17, 18	Variable Resistor (SWR) 50K ohm × 2	GM70A
VR33	Variable Resistor (CALIB) 50K ohm	V12M4-IN10SB50K
VR16	Semi Variable Resistor 200 ohm	SVR200S3

DESIGNATION	PARTS NAME	PARTS NO.
VR15	Semi Variable Resistor 500 ohm	SVR500S3
VR12, 31	Semi Variable Resistor 1K ohm	SVR001KS3
VR7, 14	Semi Variable Resistor 2K ohm	SVR002KS3
VR8, 13, 24, 29, 32	Semi Variable Resistor 5K ohm	SVR005KS3
VR20, 21, 25	Semi Variable Resistor 10K ohm	SVR010KS3
VR1, 4, 9, 10	Semi Variable Resistor 50K ohm	SVR050KS3
VR5, 23, 26, 27	Semi Variable Resistor 100K ohm	SVR100KS3
VR19	Semi Variable Resistor 200K ohm	SVR200KS2
VR11	Semi Variable Resistor 100K ohm	SVR100KS2
L1, 2	RX. RF. Tuning Coil	361-051
L3	RX. RF. Tuning Coil	361-052
L4, 6	RX. Mixing/RX. FM. Det. Coil	011-904
L5	RX. AM Det. Coil	361-006
L7	VCO. Mixing Choke Coil	424-601
L8	TX. Mixing Coil	361-053
L9	TX. Mixing output Coil	361-054
L10	TX. Buffer Coil	361-055
L11, 13	TX. Drive RFC.	010-907
L12	TX. PRI. Drive Coil	005-907
L14	TX. Drive Coil	361-801
L15, 16, 17	TX. LPF, Coil	152-903
L19, 28	TX. RF. Choke Coil/VCO, Mixing, Filter choke Coil	005-903
L21, 22	Booster LPF, Coil	361-901
L23	Booster RF Choke Coil	089-916
L26	VCO Coil	361-001
L27	VCO AMP. Coil	361-056
L29	11.3MHz OSC. AMP, Coil	011-351
L30	11.3MHz. OSC. Coil	361-057
L18, 20	TX. Power Input/TX. Power Output Coil	OP13-12-5-8H
L24	VSWR. Pick up Coil	280-702
L25	Power Choke Coil	E1-24
PL1	Meter Lamp	554700
PL2	VSWR. Indicator Lamp	554700
MP-443	Front Frame	524405
MP-592	Front Plate (R)	544683
MP-593	Front Plate (L)	554780
MP-594	Back Plate	544682
MP-595	Chassis Frame	542101
MP-107	Mounting Bracket	484085

DESIGNATION	PARTS NAME	PARTS NO.
MP-596	Cabinet Cover (Upper)	543091
MP-597	Cabinet Cover (Lower)	552104
MP-540	Back Pannel	534560
MP-221	Meter Lamp Reflection Plate	484063
MP-541	Heat Sink	534557
MP-457	Booster Chassis	523060
MP-353	Heatsink (A)	494251
MP-543	Mode SW. Mounting Plate	534561
MP-117	Knob for Channel Selector	484116
MP-17	Knob for vol./Rit./Mode Control	474011
MP-307	Knob for Squ. Control	494199
MP-598	Shield Case	543092
MP-599	Shield Case Cover	544664
MP-600	Shield Plate	543094
MP-601	Mounting Bracket for Speaker	544657
MP-110	Mounting Bracket for Meter	484064
MP-130	Screw for Mounting Bracket	484098
MP-548	Microphone Hanger	484056
MP-549	Lamp Holder	484088
MP-550	Spacer	534517
MP-118	Nut for Frequency Selector	484073
MP-551	Spacer for Booster	534564
MP-552	Brass Bobbin	534566
MP-602	Acrylic Resin Plate	544681
MP-462	Booster Chassis Cover	524421
MP-603	Meter Fixing Plate	544660
MP-610	Step Selector Knob	TK-1124
MP-452, 453	Shield Plate (C. D)	524430
MP-604	Shield Plate (F)	544654
MP-605	Meter Fixing Plate Spacer	544661
MP-606	Step Selector SW Spacer	544663
MP-607	Meter Spacer	544668
MP-608	SP. Net	544686
MP-609	SP. Cover	484050

—MEMO—



**SOMMERKAMP ELECTRONIC SAS**

CH-6903 LUGANO, P.O. BOX 176

SWITZERLAND

TEL.91 688543 TELEX:79314